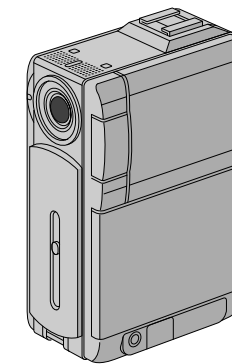


SERVICE MANUAL

DIGITAL VIDEO CAMERA

GR-DVP1EG/EK, DVP3EG/EK

GR-DVP1EG/EK, DVP3EG/EK



Mini DV PAL
 DSC
 DIGITAL
 STILL CAMERA

SPECIFICATIONS

Camcorder		For Connectors	
For General		AV	
Power supply	: DC 6.3 V \equiv (Using AC Power Adapter/Charger) DC 7.2 V \equiv (Using battery pack)	Video output	: 1 V (p-p), 75 Ω , analogue
Power consumption		Audio output	: 300 mV (rms), 1 k Ω , analogue, stereo
LCD monitor off, viewfinder on	: Approx. 4.1 W	DV	
LCD monitor on, viewfinder off	: Approx. 5.0 W	Input/output (GR-DVP3 only)	: 4-pin, IEEE 1394 compliant
Dimensions (W x H x D)	: 43 mm x 115 mm x 80 mm (with the LCD monitor closed and the viewfinder pushed back in)	Output (GR-DVP1 only)	: 4-pin, IEEE 1394 compliant
Weight	: Approx. 340 g (without grip belt, battery and cassette) Approx. 410 g (incl. grip belt, battery and cassette)	AC power adapter/charger AA-V100EG or AA-V100EK	
Operating temperature	: 0°C to 40°C	Power requirement	: AC 110 V to 240 V \sim , 50 Hz/60 Hz
Operating humidity	: 35% to 80%	Power consumption	: 23 W
Storage temperature	: -20°C to 50°C	Output	
Pickup	: 1/4" CCD	Charge	: DC 7.2 V \equiv , 1.2 A
Lens	: F 1.8, f = 3.7 mm to 37 mm, 10:1 power zoom lens (It is not possible to attach any lens filter or conversion lens.)	VTR	: DC 6.3 V \equiv , 1.8 A
LCD monitor	: 2" diagonally measured, LCD panel/TFT active matrix system	Dimensions (W x H x D)	: 68 mm x 44 mm x 110 mm
Viewfinder	: Electronic viewfinder with 0.44" colour LCD	Weight	: Approx. 250 g (AA-V100EG) Approx. 325 g (AA-V100EK)
Speaker	: Monaural	Docking Station CU-V507U	
For Digital Video Camera		For General	
Format	: DV format (SD mode)	Dimensions (W x H x D)	: 48.4 mm x 36 mm x 79 mm
Signal format	: PAL standard	Weight	: Approx. 53 g
Recording/Playback format	: Video: Digital component recording Audio: PCM digital recording, 32 kHz 4-channel (12-bit), 48 kHz 2-channel (16-bit)	For Connectors	
Cassette	: Mini DV cassette	PHONE	
Tape speed	: SP: 18.8 mm/s LP: 12.5 mm/s	Headphone output	: ϕ 3.5 mm, stereo
Maximum recording time (using 80 min. cassette)	: SP: 80 min. LP: 120 min.	USB	: TYPE B
For Digital Still Camera		S-VIDEO OUT	: Y: 1 V (p-p), 75 Ω , analogue output C: 0.29 V (p-p), 75 Ω , analogue output
Storage media	: SD Memory Card/MultiMediaCard	EDIT	: ϕ 3.5 mm, 2-pole
Compression system	: Still image: JPEG (compatible) Moving image: MPEG4 (compatible)	<i>Specifications shown are for SP mode unless otherwise indicated. E & O.E. Design and specifications subject to change without notice.</i>	
File size	: 2 modes (XGA: 1024 x 768 pixels/VGA: 640 x 480 pixels)		
Picture quality	: 2 modes (FINE/STANDARD)		
Approximate number of storable images (with the provided memory card [8 MB], with Sound Effects pre-stored)			
FINE	: 37 (VGA), 16 (XGA)		
STANDARD	: 105 (VGA), 51 (XGA)		
<i>For other memory cards, see pg. 17.</i>			

TABLE OF CONTENTS

Section	Title	Page	Section	Title	Page
Important Safety Precautions			4. CHARTS AND DIAGRAMS		
INSTRUCTIONS			NOTES OF SCHEMATIC DIAGRAM		4-1
1. DISASSEMBLY			CIRCUIT BOARD NOTES		4-2
1.1	BEFORE ASSEMBLY AND DISASSEMBLY	1-1	4.1	BOARD INTERCONNECTIONS	4-3
1.1.1	Precautions	1-1	4.2	SYSCON-CPU SCHEMATIC DIAGRAM	4-5
1.1.2	Assembly and disassembly	1-1	4.3	MSD-CPU SCHEMATIC DIAGRAM	4-7
1.1.3	Destination of connectors	1-1	4.4	MDA SCHEMATIC DIAGRAM	4-9
1.1.4	Disconnection of Connectors (Wires)	1-1	4.5	DV MAIN SCHEMATIC DIAGRAM	4-11
1.2	JIGS AND TOOLS REQUIRED FOR DISASSEMBLY, ASSEMBLY AND ADJUSTMENT	1-2	4.6	PRE/REC SCHEMATIC DIAGRAM	4-13
1.2.1	Tools required for adjustments	1-2	4.7	VIDEO OUT SCHEMATIC DIAGRAM	4-15
1.3	DISASSEMBLY/ASSEMBLY OF CABINET PARTS AND BOARD ASSEMBLY	1-2	4.8	CAM. DSP SCHEMATIC DIAGRAM	4-17
1.3.1	Disassembly flow chart	1-2	4.9	TG/VDR SCHEMATIC DIAGRAM	4-19
1.3.2	Disassembly method	1-3	4.10	VF MAIN SCHEMATIC DIAGRAM	4-21
1.4	DISASSEMBLY OF ⑤ MONITOR ASSEMBLY	1-8	4.11	REG CON SCHEMATIC DIAGRAM	4-23
1.4.1	⑤ Monitor assembly/Hinge assembly	1-8	4.12	REG SCHEMATIC DIAGRAM	4-25
1.4.2	Hinge assembly	1-8	4.13	MONITOR MAIN SCHEMATIC DIAGRAM	4-27
1.5	DISASSEMBLY OF ⑩ E. VF ASSEMBLY	1-9	4.14	DSC SCHEMATIC DIAGRAM	4-29
1.5.1	⑩E. VF assembly	1-9	4.15	AUDIO MP3 SCHEMATIC DIAGRAM	4-31
1.6	DISASSEMBLY OF ⑪ OP BLOCK ASSEMBLY/CCD BOARD ASSEMBLY	1-10	4.16	USBDRV SCHEMATIC DIAGRAM	4-33
1.6.1	Precautions	1-10	4.17	W/B SCHEMATIC DIAGRAM	4-35
1.6.2	How to remove OP block assembly and CCD board assembly	1-10	4.18	CCD SCHEMATIC DIAGRAM	4-36
1.6.3	How to install ⑪ OP block assembly and CCD board assembly	1-10	4.19	WBSE/SW SCHEMATIC DIAGRAM	4-37
1.6.4	Replacement of service parts	1-10	4.20	AUDIO AD/DA SCHEMATIC DIAGRAM	4-39
1.7	EMERGENCY DISPLAY	1-11	4.21	MAIN AUDIO SCHEMATIC DIAGRAM	4-41
1.8	SERVICE KNOW-HOW	1-12	4.22	OPDRV SCHEMATIC DIAGRAM	4-43
1.9	SERVICE NOTE	1-14	4.23	BOTTOM SCHEMATIC DIAGRAM	4-45
2. MECHANISM ADJUSTMENT			4.24	MONITOR SCHEMATIC DIAGRAM	4-47
2.1	PRELIMINARY REMARKS ON ADJUSTMENT AND REPAIR	2-1	4.25	OPE.COVER UNIT AND SUB OPE. UNIT SCHEMATIC DIAGRAMS	4-49
2.1.1	Precautions	2-1	4.26	MAIN CIRCUIT BOARD	4-51
2.1.2	Notes on procedure for disassembly/assembly	2-1	4.27	AUDIO CIRCUIT BOARD	4-57
2.2	JIGS AND TOOLS REQUIRED FOR DISASSEMBLY, ASSEMBLY AND ADJUSTMENT	2-2	4.28	BOTTOM CIRCUIT BOARD	4-59
2.2.1	Tools required for adjustments	2-2	4.29	MONITOR CIRCUIT BOARD	4-61
2.3	DISASSEMBLY/ASSEMBLY OF MECHANISM ASSEMBLY	2-3	4.30	CCD AND EJECT CIRCUIT BOARDS	4-62
2.3.1	General statement	2-3	4.31	VOLTAGE CHARTS	4-63
2.3.2	Explanation of mechanism mode	2-3	4.32	POWER SYSTEM BLOCK DIAGRAM	4-65
2.3.3	Mechanism timing chart	2-4	4.33	VIDEO SYSTEM BLOCK DIAGRAM	4-67
2.4	DISASSEMBLING PROCEDURE TABLE	2-5	5. PARTS LIST		
2.4.1	Disassembly/assembly	2-7	5.1	PACKING AND ACCESSORY ASSEMBLY <M1>	5-1
2.4.2	List of procedures for disassembly	2-13	5.2	FINAL ASSEMBLY <M2>	5-2
2.5	CHECKUP AND ADJUSTMENT OF MECHANISM PHASE	2-14	5.3	MECHANISM ASSEMBLY <M3>	5-6
2.6	MECHANISM ADJUSTMENTS	2-15	5.4	ELECTRONIC VIEWFINDER ASSEMBLY <M4>	5-8
2.6.1	Adjustment of the slide guide plate	2-15	5.5	MONITOR ASSEMBLY <M5>	5-9
2.6.2	Adjustment of the Tension Arm and Pad Arm Assemblies ...	2-16	5.6	ELECTRICAL PARTS LIST	5-10
2.6.3	Adjustment of the Slide Lever 2	2-16	MAIN BOARD ASSEMBLY <01>		5-10
2.7	JIG CONNECTOR CABLE CONNECTION	2-17	AUDIO BOARD ASSEMBLY <02>		5-18
2.8	SERVICE NOTE	2-18	BOTTOM BOARD ASSEMBLY <03>		5-21
3. ELECTRICAL ADJUSTMENT			MONITOR BOARD ASSEMBLY <04>		5-21
3.1	PRECAUTION	3-1	CCD BOARD ASSEMBLY <05>		5-21
3.2	SETUP	3-2	EJECT BOARD ASSEMBLY <06>		5-21
			6. AC POWER ADAPTER (AA-V100EG/EK)		
			6.1	CABINET ASSEMBLY <MA>	6-1
			6.2	SCHEMATIC DIAGRAM	6-2
			6.3	CIRCUIT BOARD	6-4
			6.4	ELECTRICAL PARTS LIST	6-5
			MAIN & TERMINAL BOARD ASSEMBLY <91>		6-5

The following table lists the differing points between Models GR-DVP1EG/EK and GR-DVP3EG/EK in this series.

	GR-DVP1EG	GR-DVP1EK	GR-DVP3EG	GR-DVP3EK
DV INPUT	NOT USED	NOT USED	USED	USED
AC ADAPTER CHARGER	AA-V100EG	AA-V100EK	AA-V100EG	AA-V100EK
BODY COLOR	SILVER	SILVER	DARK GRAY/SILVER	DARK GRAY/SILVER
BATTERY PACK (COLOR)	SILVER	SILVER	DARK GRAY	DARK GRAY

Important Safety Precautions

Prior to shipment from the factory, JVC products are strictly inspected to conform with the recognized product safety and electrical codes of the countries in which they are to be sold. However, in order to maintain such compliance, it is equally important to implement the following precautions when a set is being serviced.

● Precautions during Servicing

1. Locations requiring special caution are denoted by labels and inscriptions on the cabinet, chassis and certain parts of the product. When performing service, be sure to read and comply with these and other cautionary notices appearing in the operation and service manuals.

2. Parts identified by the \triangle symbol and shaded (■) parts are critical for safety.

Replace only with specified part numbers.

Note: Parts in this category also include those specified to comply with X-ray emission standards for products using cathode ray tubes and those specified for compliance with various regulations regarding spurious radiation emission.

3. Fuse replacement caution notice.
Caution for continued protection against fire hazard.
Replace only with same type and rated fuse(s) as specified.

4. Use specified internal wiring. Note especially:

- 1) Wires covered with PVC tubing
- 2) Double insulated wires
- 3) High voltage leads

5. Use specified insulating materials for hazardous live parts. Note especially:

- | | | |
|--------------------|--------------------------------------|------------|
| 1) Insulation Tape | 3) Spacers | 5) Barrier |
| 2) PVC tubing | 4) Insulation sheets for transistors | |

6. When replacing AC primary side components (transformers, power cords, noise blocking capacitors, etc.) wrap ends of wires securely about the terminals before soldering.

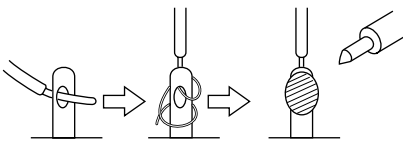


Fig.1

7. Observe that wires do not contact heat producing parts (heatsinks, oxide metal film resistors, fusible resistors, etc.)

8. Check that replaced wires do not contact sharp edged or pointed parts.

9. When a power cord has been replaced, check that 10-15 kg of force in any direction will not loosen it.

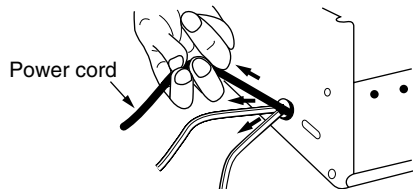


Fig.2

10. Also check areas surrounding repaired locations.

11. Products using cathode ray tubes (CRTs)
In regard to such products, the cathode ray tubes themselves, the high voltage circuits, and related circuits are specified for compliance with recognized codes pertaining to X-ray emission. Consequently, when servicing these products, replace the cathode ray tubes and other parts with only the specified parts. Under no circumstances attempt to modify these circuits. Unauthorized modification can increase the high voltage value and cause X-ray emission from the cathode ray tube.

12. Crimp type wire connector

In such cases as when replacing the power transformer in sets where the connections between the power cord and power transformer primary lead wires are performed using crimp type connectors, if replacing the connectors is unavoidable, in order to prevent safety hazards, perform carefully and precisely according to the following steps.

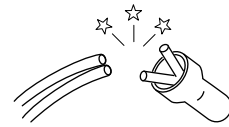
1) Connector part number : E03830-001

2) Required tool : Connector crimping tool of the proper type which will not damage insulated parts.

3) Replacement procedure

(1) Remove the old connector by cutting the wires at a point close to the connector.

Important : Do not reuse a connector (discard it).



cut close to connector

Fig.3

(2) Strip about 15 mm of the insulation from the ends of the wires. If the wires are stranded, twist the strands to avoid frayed conductors.

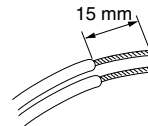


Fig.4

(3) Align the lengths of the wires to be connected. Insert the wires fully into the connector.

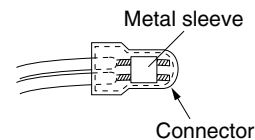


Fig.5

(4) As shown in Fig.6, use the crimping tool to crimp the metal sleeve at the center position. Be sure to crimp fully to the complete closure of the tool.

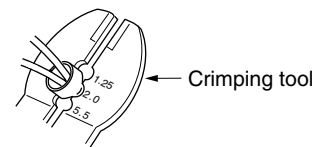


Fig.6

(5) Check the four points noted in Fig.7.

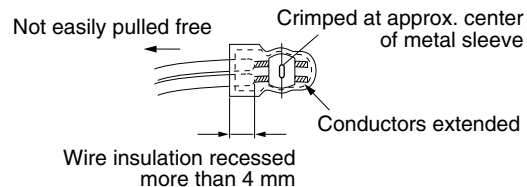


Fig.7

● Safety Check after Servicing

Examine the area surrounding the repaired location for damage or deterioration. Observe that screws, parts and wires have been returned to original positions. Afterwards, perform the following tests and confirm the specified values in order to verify compliance with safety standards.

1. Insulation resistance test

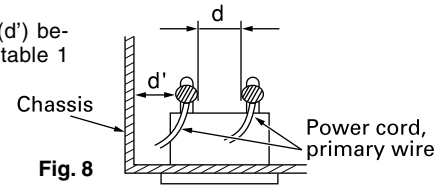
Confirm the specified insulation resistance or greater between power cord plug prongs and externally exposed parts of the set (RF terminals, antenna terminals, video and audio input and output terminals, microphone jacks, earphone jacks, etc.). See table 1 below.

2. Dielectric strength test

Confirm specified dielectric strength or greater between power cord plug prongs and exposed accessible parts of the set (RF terminals, antenna terminals, video and audio input and output terminals, microphone jacks, earphone jacks, etc.). See table 1 below.

3. Clearance distance

When replacing primary circuit components, confirm specified clearance distance (d), (d') between soldered terminals, and between terminals and surrounding metallic parts. See table 1 below.

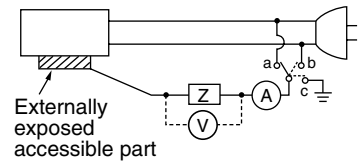


4. Leakage current test

Confirm specified or lower leakage current between earth ground/power cord plug prongs and externally exposed accessible parts (RF terminals, antenna terminals, video and audio input and output terminals, microphone jacks, earphone jacks, etc.).

Measuring Method : (Power ON)

Insert load Z between earth ground/power cord plug prongs and externally exposed accessible parts. Use an AC voltmeter to measure across both terminals of load Z. See figure 9 and following table 2.

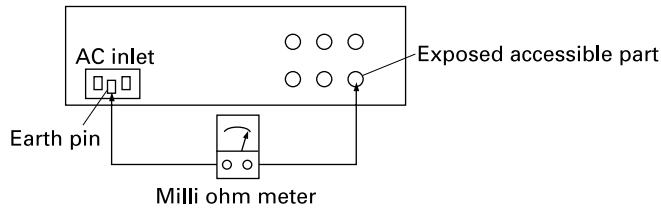


5. Grounding (Class 1 model only)

Confirm specified or lower grounding impedance between earth pin in AC inlet and externally exposed accessible parts (Video in, Video out, Audio in, Audio out or Fixing screw etc.).

Measuring Method:

Connect milli ohm meter between earth pin in AC inlet and exposed accessible parts. See figure 10 and grounding specifications.



Grounding Specifications

Region	Grounding Impedance (Z)
USA & Canada	$Z \leq 0.1 \text{ ohm}$
Europe & Australia	$Z \leq 0.5 \text{ ohm}$

AC Line Voltage	Region	Insulation Resistance (R)	Dielectric Strength	Clearance Distance (d), (d')
100 V	Japan	$R \geq 1 \text{ M}\Omega/500 \text{ V DC}$	AC 1 kV 1 minute	$d, d' \geq 3 \text{ mm}$
100 to 240 V			AC 1.5 kV 1 minute	$d, d' \geq 4 \text{ mm}$
110 to 130 V	USA & Canada	$1 \text{ M}\Omega \leq R \leq 12 \text{ M}\Omega/500 \text{ V DC}$	AC 1 kV 1 minute	$d, d' \geq 3.2 \text{ mm}$
110 to 130 V 200 to 240 V	Europe & Australia	$R \geq 10 \text{ M}\Omega/500 \text{ V DC}$	AC 3 kV 1 minute (Class II) AC 1.5 kV 1 minute (Class I)	$d \geq 4 \text{ mm}$ $d' \geq 8 \text{ mm}$ (Power cord) $d' \geq 6 \text{ mm}$ (Primary wire)

Table 1 Specifications for each region

AC Line Voltage	Region	Load Z	Leakage Current (i)	a, b, c
100 V	Japan	1 kΩ	$i \leq 1 \text{ mA rms}$	Exposed accessible parts
110 to 130 V	USA & Canada	0.15 μF, 1.5 kΩ	$i \leq 0.5 \text{ mA rms}$	Exposed accessible parts
110 to 130 V 220 to 240 V	Europe & Australia	2 kΩ	$i \leq 0.7 \text{ mA peak}$ $i \leq 2 \text{ mA dc}$	Antenna earth terminals
		50 kΩ	$i \leq 0.7 \text{ mA peak}$ $i \leq 2 \text{ mA dc}$	Other terminals

Table 2 Leakage current specifications for each region

Note: These tables are unofficial and for reference only. Be sure to confirm the precise values for your particular country and locality.

SECTION 1 DISASSEMBLY

1.1 BEFORE ASSEMBLY AND DISASSEMBLY

1.1.1 Precautions

1. Be sure to remove the power supply unit prior to mounting and soldering of parts.
2. When removing a component part that needs to disconnect the connector and to remove the screw for removing itself, first disconnect the connecting wire from the connector and then remove the screw beforehand.
3. When connecting and disconnecting the connectors, be careful not to damage the wire.
4. Carefully remove and handle the part to which some spacer or shield is attached for reinforcement or insulation.
5. When replacing chip parts (especially IC parts), desolder completely first (to prevent peeling of the pattern).
6. Tighten screws properly during the procedures.
Unless specified otherwise, tighten screws at a torque of 0.078N·m(0.8kgf·cm).

1.1.2 Assembly and disassembly

STEP No.	PART	Fig.No.	POINT	NOTE
①	COVER(UNDER)	Fig.1-3-1	(S①)	—
②	COVER(SHOE)	Fig.1-3-2	2(S②),(L②a),(L②b)	—
③	MIC COVER ASSY		(S③a),2(S③b)	—

↑ (1)
↑ (2)
↑ (3)
↑ (4)
↑ (5)

- (1) Indicate the disassembly steps. When assembling, perform in the reverse order of these steps. This number corresponds to the number in the disassembly diagram.
- (2) Indicates the name of disassembly/assembly parts.
- (3) Indicates the number in the disassembly diagram.
- (4) Indicates parts and points such as screws, washers, springs which must be removed during disassembly/assembly.

Symbol	Name, Point
S	Screw
L	Lock, Pawl, Hook
SD	Soldering
CN	Connector

(Example)

- 2 (S①) : Remove the two screws (S①) for removing the part ①.
- CN ①a: Disconnect the connector ①a.
- SD1 : Unsolder at the point SD1.

(5) Precautions on disassembly/assembly.

1.1.3 Destination of connectors

Note: Three kinds of double-arrows in connection tables respectively show kinds of connector/wires.

- ↔ : Wire
- ⇔ : Flat wire (FPC, FFC)
- ↔ : Board to Board connector

[Example]

NOTE: Remove the parts marked in .

CONN. No.	CONNECTOR					Pin No.
CN④a	MAIN	CN107	↔	BOTTOM	CN301	50
CN④b	MAIN	CN112	⇔	SUB OPE UNIT	CN112	7

1.1.4 Disconnection of Connectors (Wires)

Connector

Pull both ends of the connector in the arrow direction, remove the lock and disconnect the flat wire.

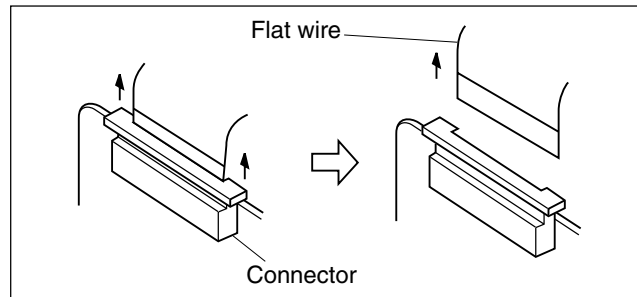


Fig. 1-1-1 Connector 1

Extend the locks in the direction of the arrow for unlocking and then pull out the wire. After removing the wire, immediately restore the locks to their original positions because the locks are apt to come off the connector.

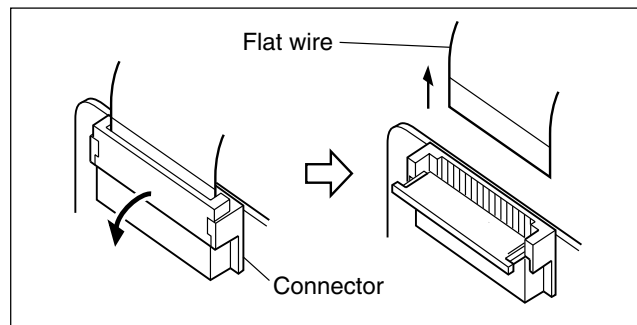


Fig. 1-1-2 Connector 2

B-B connector

Pull the board by both the sides in the direction of the arrow for disconnecting the B-B connector.

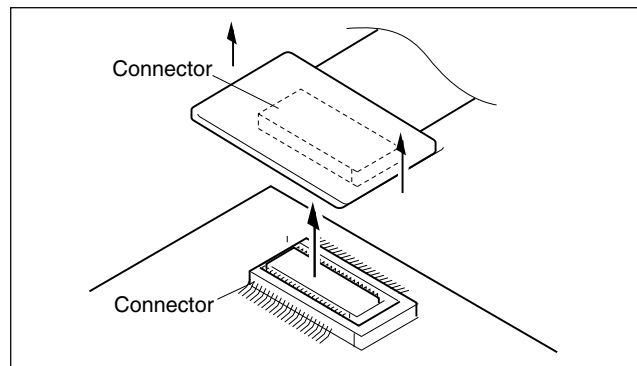


Fig. 1-1-3 Connector 3

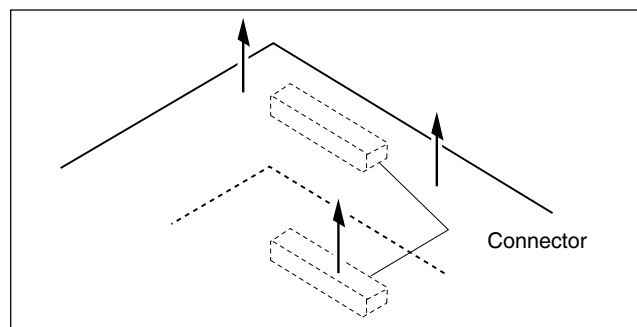


Fig. 1-1-4 Connector 4

1.2 JIGS AND TOOLS REQUIRED FOR DISASSEMBLY, ASSEMBLY AND ADJUSTMENT

1.2.1 Tools required for adjustments

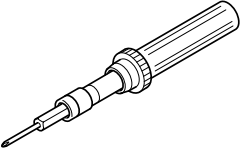
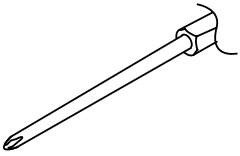
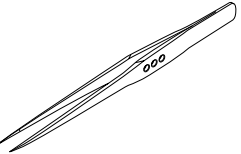
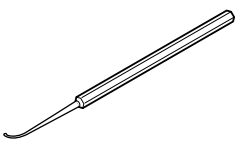
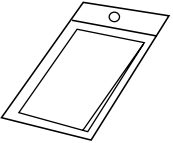
1	Torque Driver YTU94088	2	Bit YTU94088-003
			
3	Tweezers P-895	4	Chip IC Replacement Jig PTS40844-2
			
5	Cleaning Cloth KSMM-01		
			

Table 1-2-1

1. Torque driver

Be sure to use to fastening the mechanism and exterior parts because those parts must strictly be controlled for tightening torque.

2. Bit

This bit is slightly longer than those set in conventional torque drivers.

3. Tweezers

To be used for removing and installing parts and wires.

4. Chip IC replacement jig

To be used for adjustment of the camera system.

5. Cleaning cloth

Recommended cleaning cloth to wipe down the video heads, mechanism (tape transport system), optical lens surface.

1.3 DISASSEMBLY/ASSEMBLY OF CABINET PARTS AND BOARD ASSEMBLY

1.3.1 Disassembly flow chart

This flowchart indicates the disassembly step for the cabinet parts and board assembly in order to gain access to item(s) to be serviced. When reassembling, perform the step(s) in reverse order.

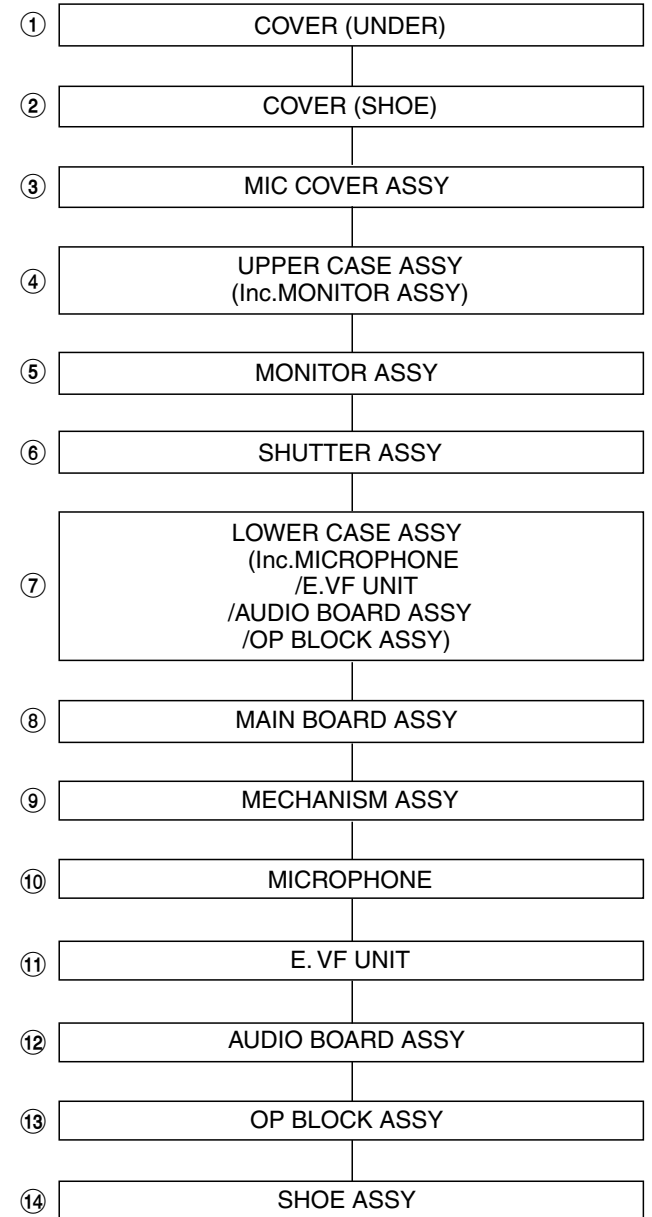


Table 1-3-1

1.3.2 Disassembly method

STEP No.	PART	Fig.No.	POINT	NOTE
①	COVER (UNDER)	Fig.1-3-1	(S①)	—
②	COVER (SHOE)	Fig.1-3-2	2(S②), (L②a), (L②b)	—
③	MIC COVER ASSY		(S③a), 2(S③b)	—
④	UPPER CASE ASSY (Inc.MONITOR ASSY)	Fig.1-3-3a	(SD CARD) (S④a), COVER (JIG) CN ④a	NOTE④a NOTE④b
		Fig.1-3-3b	2(S④b), (S④c), 2(S④b), 2(S④d) 2(S④b), (S④e) CN ④b, CN④c	NOTE④c
⑤	MONITOR ASSY	Fig.1-3-4	2(S⑤a), GUIDE(MONI), 2(S⑤b)	NOTE⑤
⑥	SHUTTER ASSY	Fig.1-3-5	(S⑥)	NOTE⑥
⑦	LOWER CASE ASSY (Inc.MICROPHONE, E. VF UNIT, AUDIO BOARD ASSY, OP BLOCK ASSY)	Fig.1-3-6	CN ⑦a,CN ⑦b.SHEET(SHUTTER) CN ⑦c, CN⑦d, 4(S⑦)	NOTE⑦
⑧	MAIN BOARD ASSY	Fig.1-3-7	SHEET(SHUTTER), 2(S⑧) (L⑧a), SHIELD ASSY, CN ⑧a, CN ⑧b, CN ⑧c, CN ⑧d 2(L⑧b), (L⑧c) CN ⑧e, CN ⑧f	—
⑨	MECHANISM ASSY		3(S⑨a),BRACKET(PRE/REC), 3(S⑨b),BRACKET(MECHA) ASSY	
⑩	MICROPHONE	Fig.1-3-8a	HOOD, SPACER, (S⑩), (S⑩) CN⑩a	NOTE⑩
⑪	E. VF UNIT		(S⑩), SPACER, CN⑩a	NOTE⑩a NOTE⑩b
⑫	AUDIO BOARD ASSY	Fig.1-3-8b	2(S⑫b), SPACER, 3(S⑫)	NOTE⑫a NOTE⑫b
⑬	OP BLOCK ASSY		CN ⑬a	NOTE⑬a NOTE⑬b
⑭	SHOE ASSY		CN ⑭a	NOTE⑭

Table 1-3-2

Note: Remove the parts marked in .

CONN. No.	CONNECTOR					Pin No.
CN④a	MAIN	CN107	↔	BOTTOM	CN301	50
CN④b	MAIN	CN112	↔	SUB OPE UNIT	-	7
CN④c	MAIN	CN113	↔	MONITOR	CN401	39/33
CN⑦a	MAIN	CN110	↔	AUDIO	CN201	120
CN⑦b	MAIN	CN111	↔	CCD	-	20
CN⑦c	MAIN	CN109	↔	OPE. COVER UNIT	-	13
CN⑦d	MAIN	CN108	↔	EJECT SW	-	2
CN⑧a	MAIN	CN102	↔	LOADING MOTOR	-	6
CN⑧b	MAIN	CN103	↔	ROTARY ENCODER	-	6
CN⑧c	MAIN	CN101	↔	HEAD	-	8
CN⑧d	MAIN	CN106	↔	SENSOR	-	16
CN⑧e	MAIN	CN105	↔	CAPSTAN MOTOR	-	18
CN⑧f	MAIN	CN104	↔	DRUM MOTOR	-	11
CN⑩a	AUDIO	CN203	↔	MICROPHONE	-	4
CN⑪a	AUDIO	CN204	↔	VF BL	CN7551	20
CN⑬a	AUDIO	CN205	↔	OP BLOCK ASSY	-	24
CN⑭a	AUDIO	CN202	↔	SHOE ASSY	-	16

Table 1-3-3

NOTE ④a: If a card is installed, remove it in advance.

NOTE ④b: Be careful not to damage the battery removal switch.

When disassembling, ensure that the lock lever is in the low position and set the battery removal switch only to the up position.

NOTE ④c: Take care of the removed screws.

NOTE ⑤: Refer to Fig. 1-4-1 for the disassembly method.

NOTE ⑥: Be careful not to damage or lose the parts.

NOTE ⑦: For the disassembly/assembly of the E. VF unit, AUDIO board assembly, and OP block assembly, see section 1.8, "SERVICE KNOW-HOW".

NOTE ⑩: Leave the OP block assembly connected to the audio board and locate it in a vacant space.

NOTE ⑪a: Be careful not to cut the FPC wire or damage any of the switches during work.

NOTE ⑪b: Refer to Fig. 1-5-1 for the disassembly method.

NOTE ⑫a: Carefully proceed with the above-mentioned work not to damage any part.

NOTE ⑫b, ⑬a, ⑭ :

When assembling, attach the OP block assembly and the shoe assembly on the AUDIO board assembly and install them together in the lower case assembly.

NOTE ⑬b: Refer to Fig. 1-6-1 for the disassembly method.

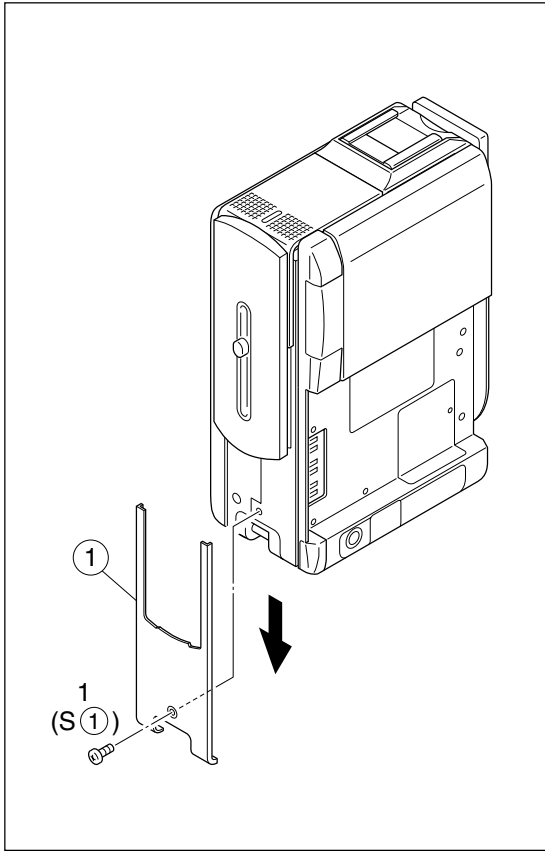


Fig. 1-3-1

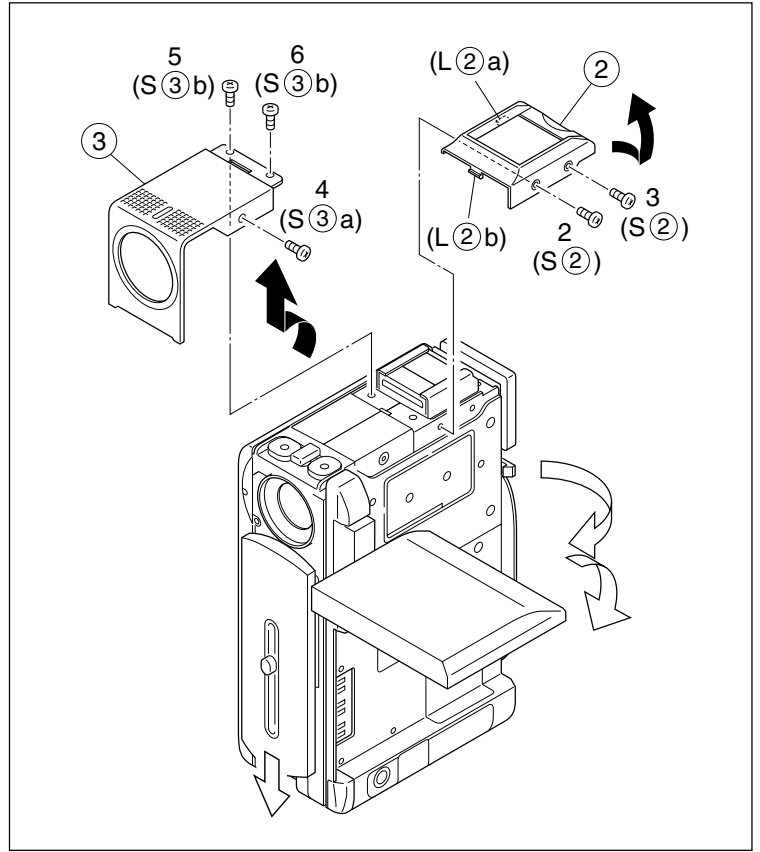


Fig. 1-3-2

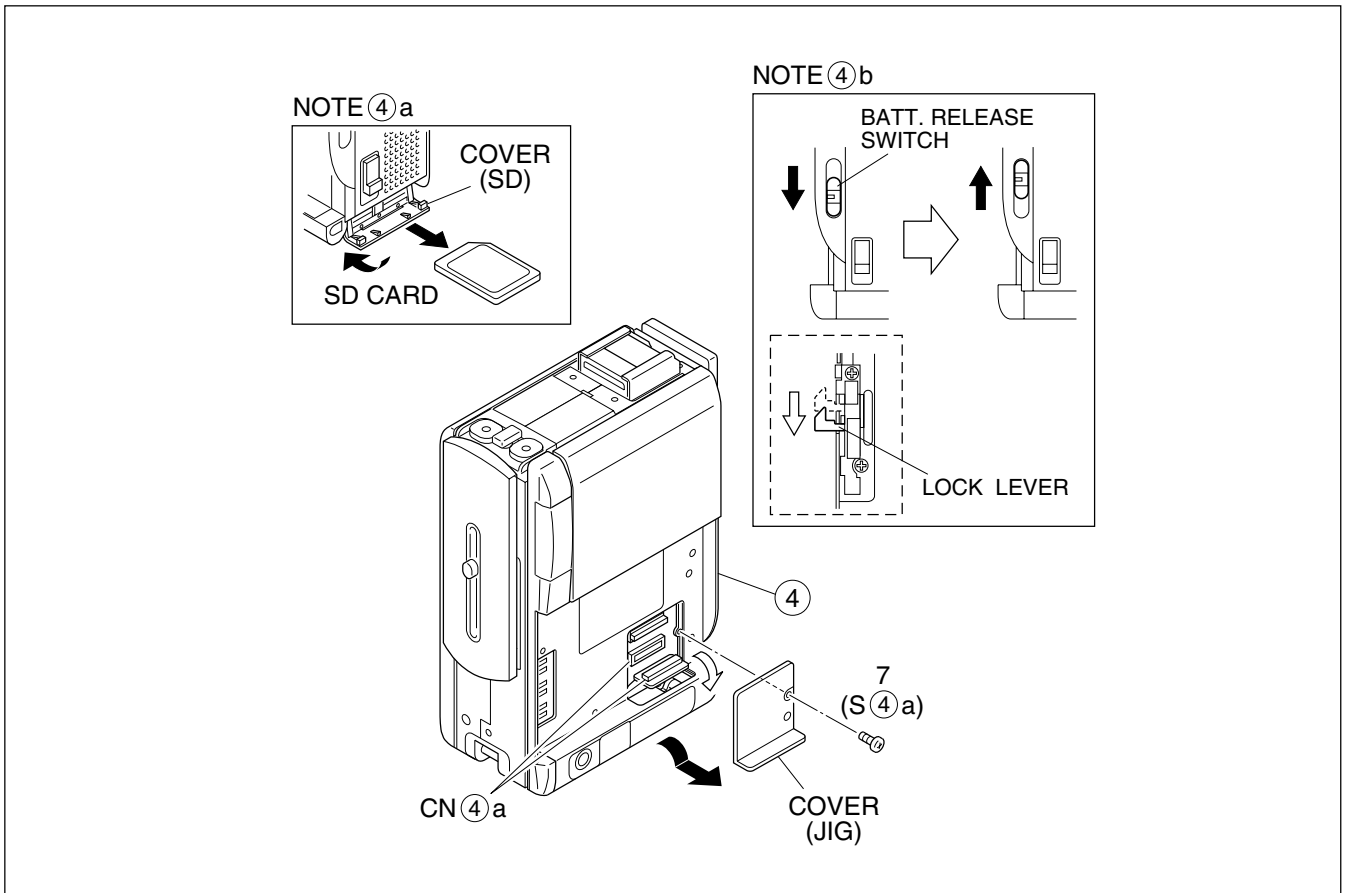


Fig. 1-3-3a

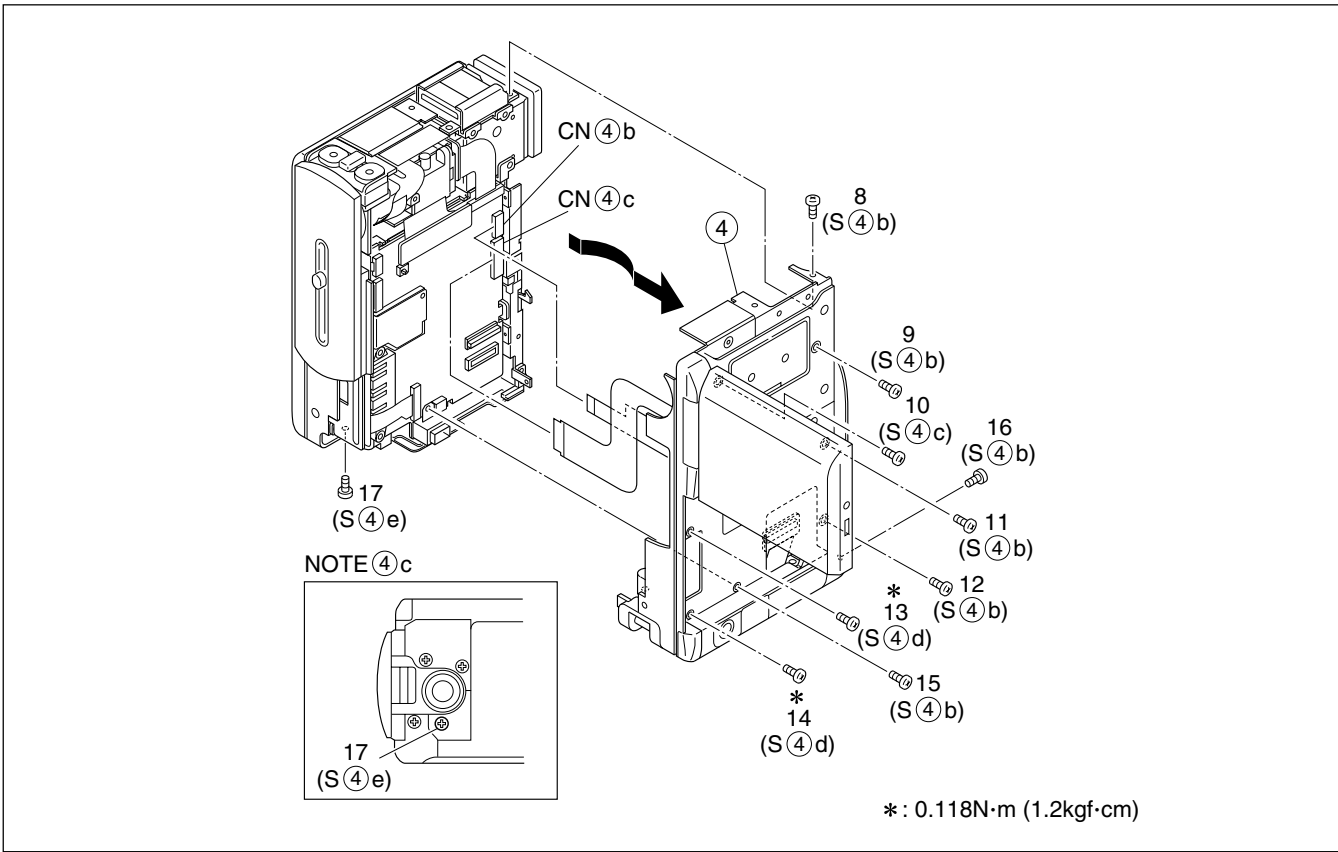


Fig. 1-3-3b

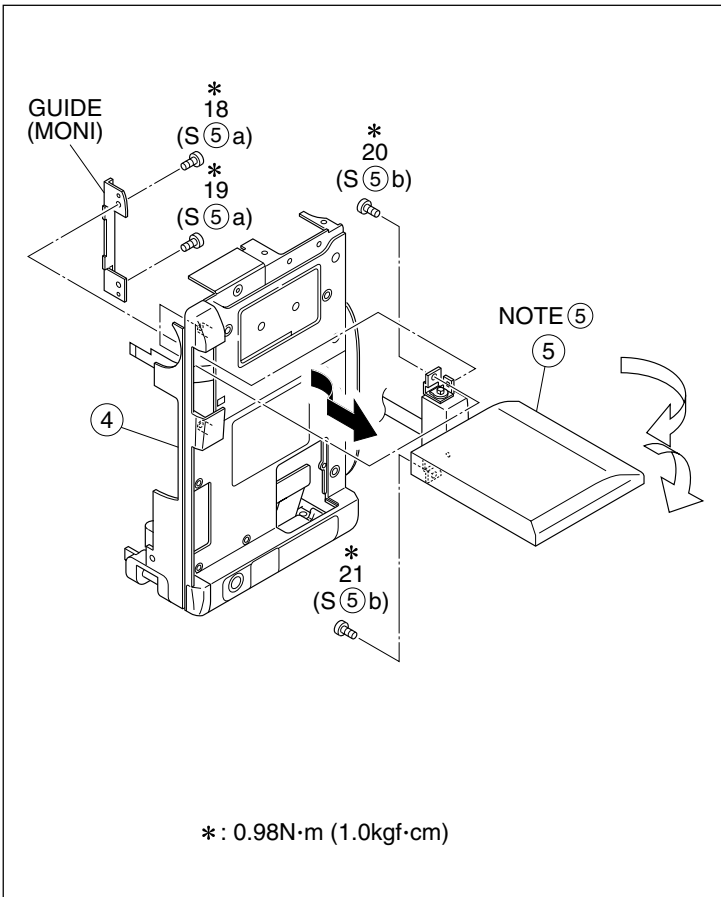


Fig. 1-3-4

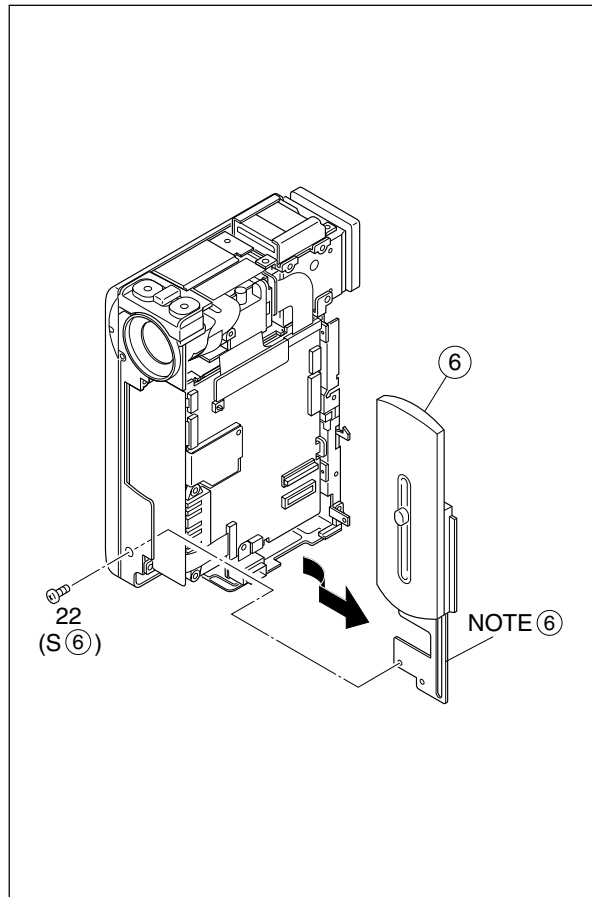


Fig. 1-3-5

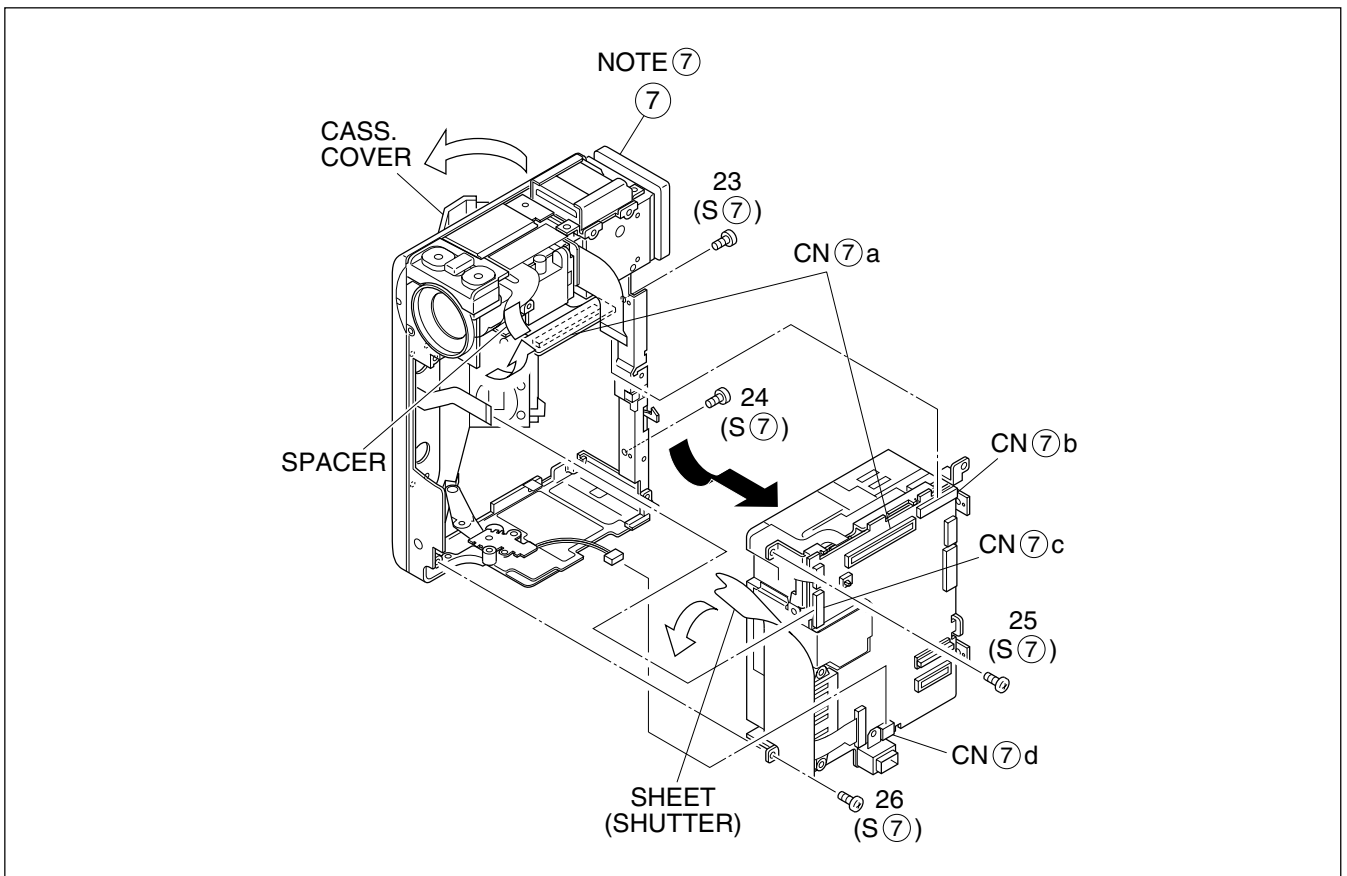


Fig. 1-3-6

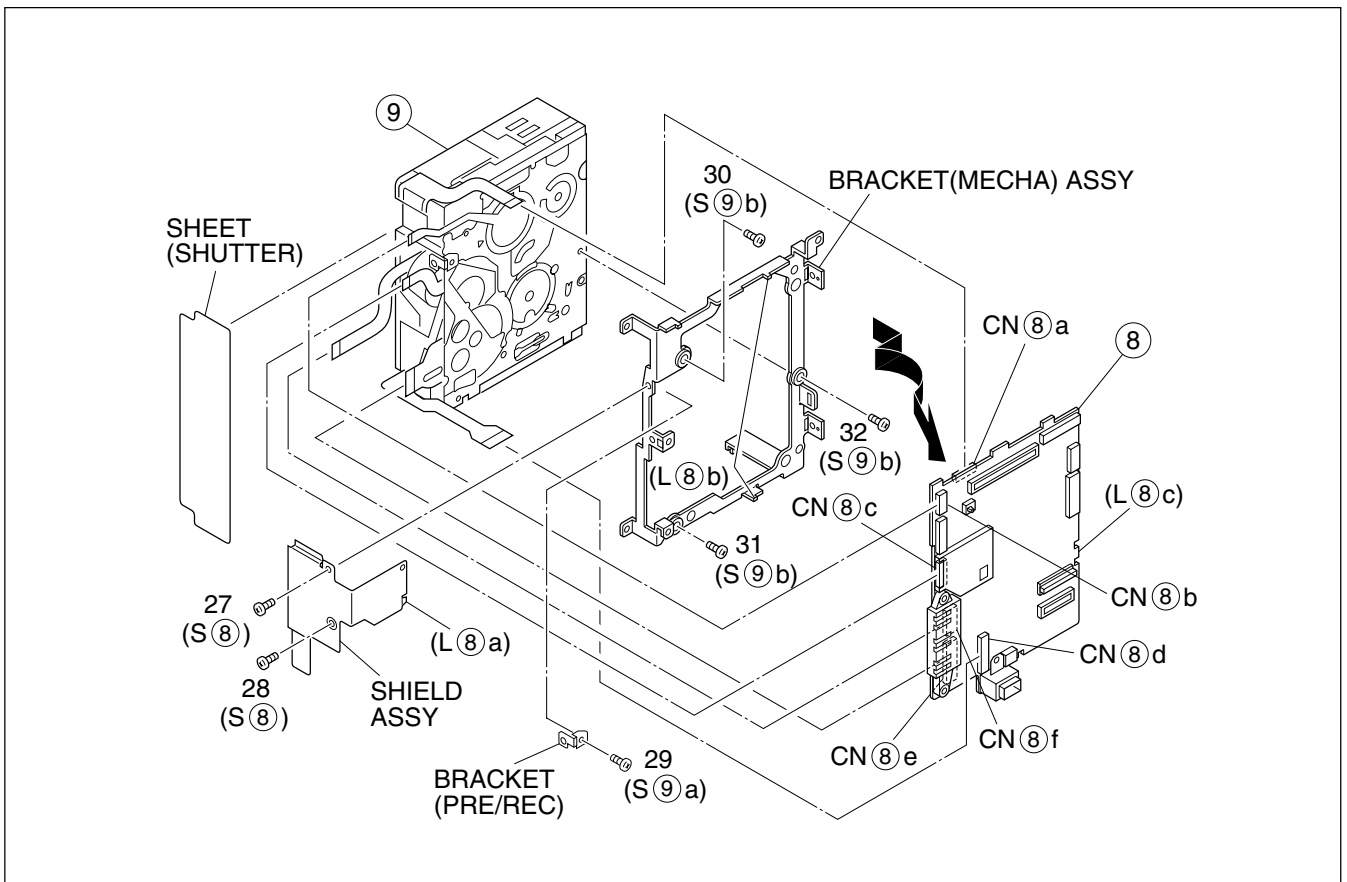


Fig. 1-3-7

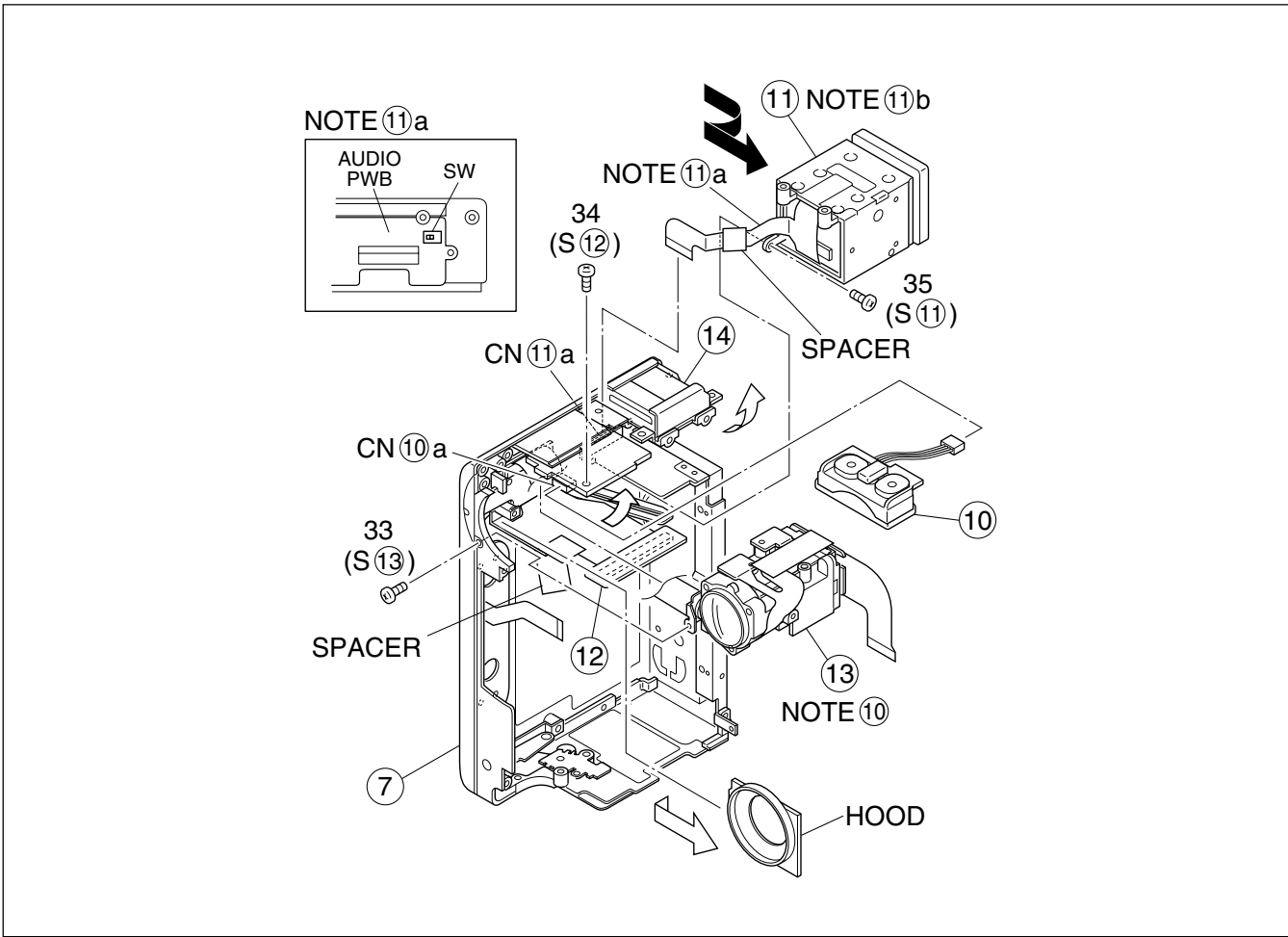


Fig. 1-3-8a

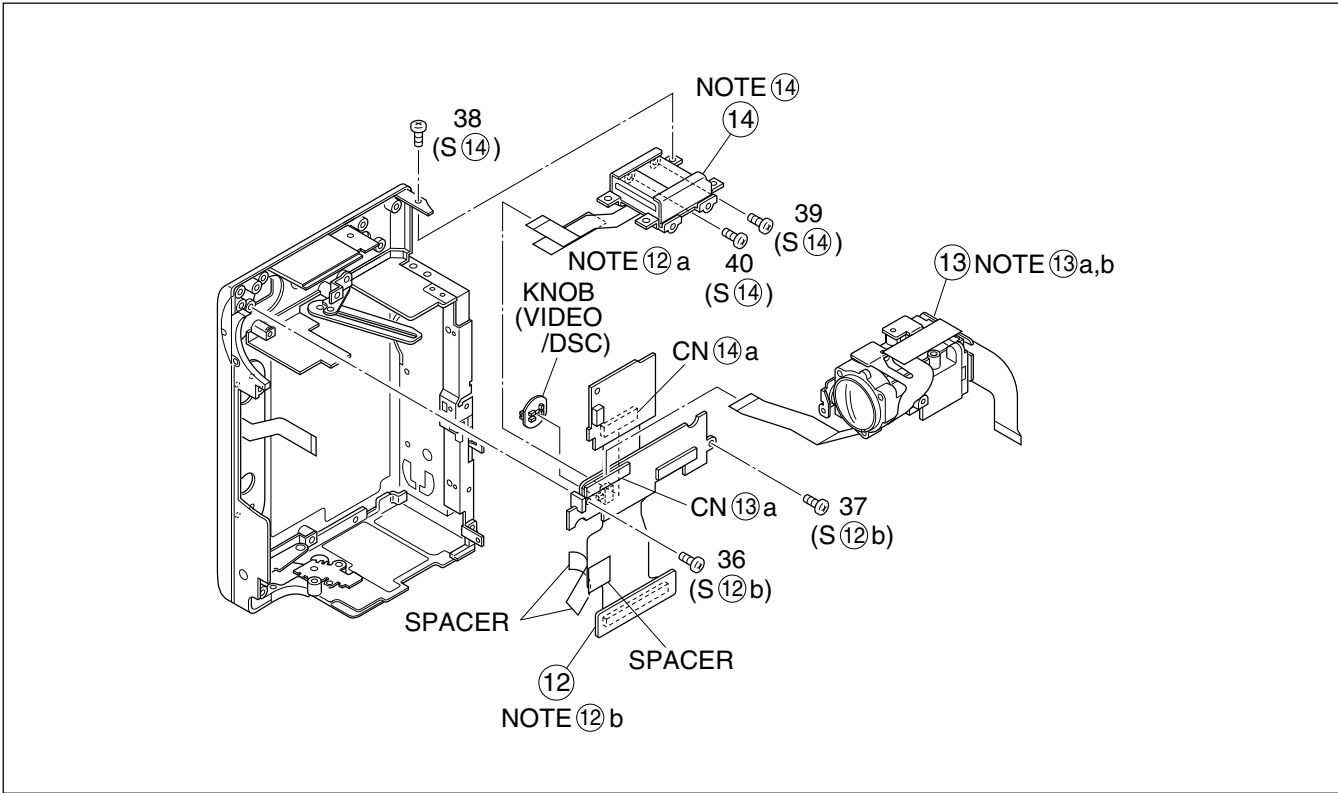


Fig. 1-3-8b

1.4 DISASSEMBLY OF ⑤ MONITOR ASSEMBLY

1.4.1 ⑤ Monitor assembly/Hinge assembly

1. Remove the three screws (1 to 3) and then remove the monitor cover by disengaging the two hooks (L⑤a, L⑤b) at the top and bottom.

Note⑤a: Be careful not to lose part (Rib).

2. Pull out the part (sensor) from the monitor case assembly.

3. Disconnect FPC from the connector CN⑤a and then remove the MONITOR board assembly and backlight.

Note⑤b: When removing the parts out of the monitor case assembly, be very careful not to damage the FPC and parts.

Note⑤c: Remove the MONITOR board assembly and backlight together unless it is needed to separate them from each other for part replacement, etc., because the two are soldered to each other.

4. Take out the LCD module, back light and monitor board assembly from the monitor case assembly. Be careful with the hooks (L⑤e, L⑤f) on the two sides. Disconnect the FPC assembly from the connector (CN5b) and remove the LCD module. Be careful with the hooks (L⑤g, L⑤h) on the two sides.

1.4.2 Hinge assembly

1. Remove the two screws (4,5) to take out the FPC assembly while removing the hinge cover.

Note⑤d: Be careful not to lose any part during the above-mentioned process.

2. Remove the hinge cover (U) from hinge assembly.

Note⑤e: Be careful not to lose any part during the above-mentioned process.

Note⑤f: When reassembling, wind the FPC assembly around the hinge assembly by three turns and a half. Be careful not to break the FPC wire during the work.

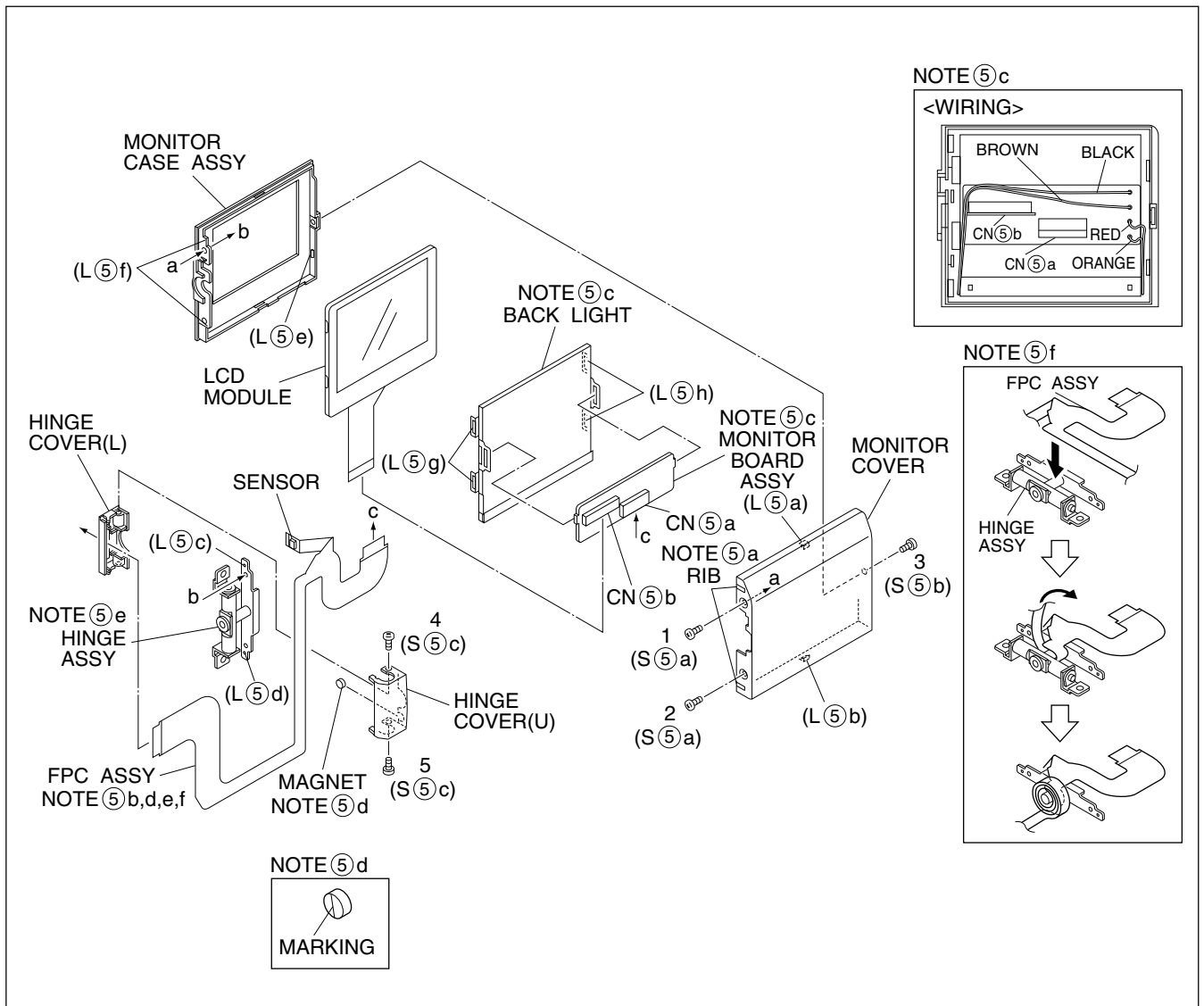


Fig. 1-4-1

1.5 DISASSEMBLY OF ⑪ E. VF ASSEMBLY

1.5.1 ⑪E. VF assembly

Note⑪a: When disassembling the E. VF assembly, remove the frame (VF) from the case/cap assembly depending on the situation.

Note⑪b: Be very careful not to get the inside of the VF soiled or dusty during and after disassembling the E. VF assembly.

1. Draw the frame (VF) out of the case assembly.
2. Remove the eyecup and pull out the guide (VF).

<Case assembly>

3. While holding the guide (VF), pull out the case assembly, remove the two screws (1, 2) and remove the cap (VF).
4. Remove the three screws (3-5) and draw out the eye-piece sub assembly.

Note⑪c: A lens assembly and a lever are mounted on the eye-piece sub assembly. When removing this assembly, be careful not to damage them.

5. Draw out the guide (VF).

<Frame (VF)>

6. Remove the screw (6) first and then LCD module/holder (LCD).
7. Get the two hooks (L⑪a, L⑪b) disengaged and then remove the holder (LCD)

Note⑪d: Carefully proceed with the above-mentioned work not to damage any part.

8. Disconnect the connector (CN⑪b) and remove the LCD module.

Note⑪e: Pay heed the parts not to damage any thing.

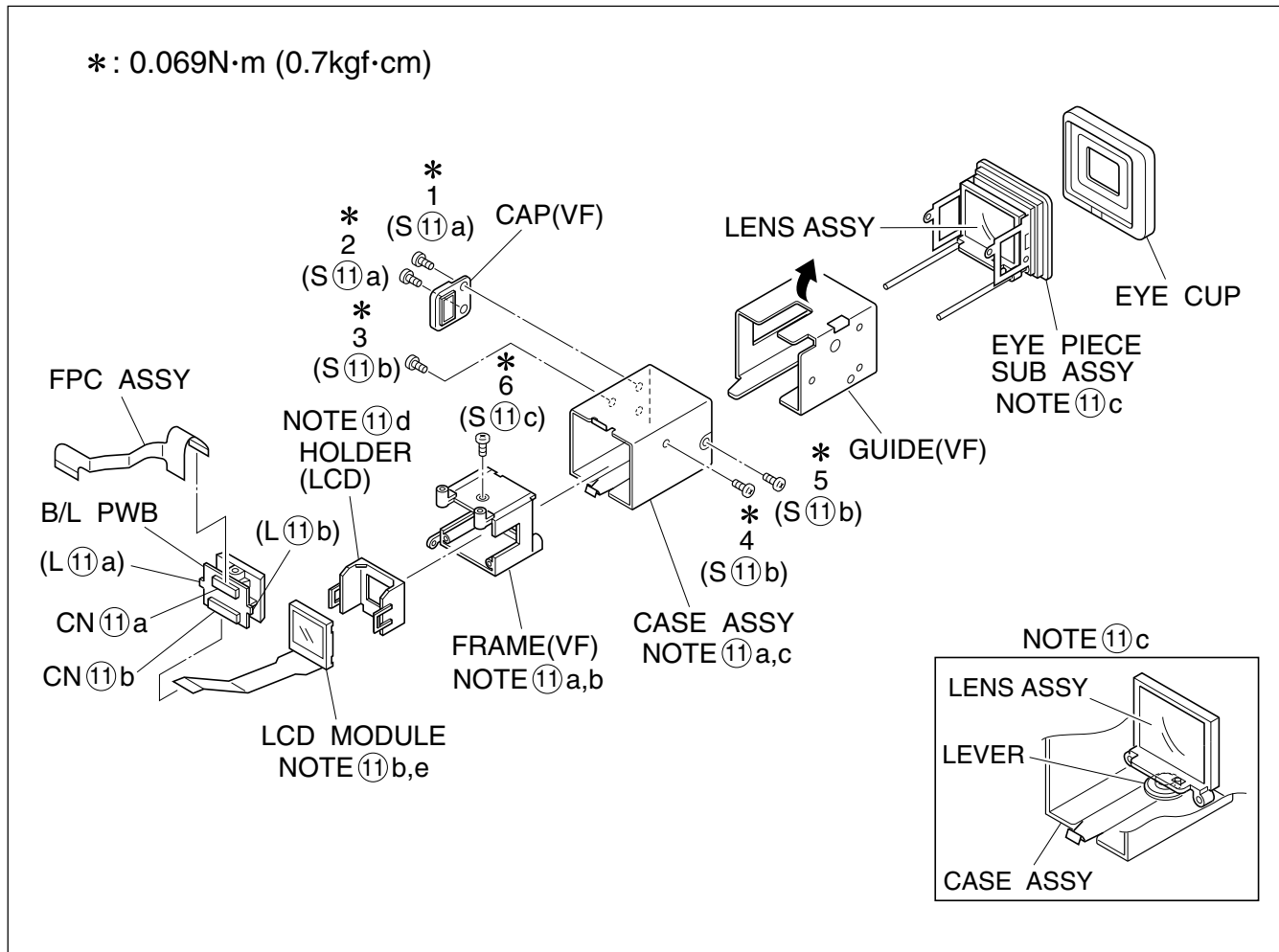


Fig. 1-5-1

1.6 DISASSEMBLY OF ⑬ OP BLOCK ASSEMBLY/CCD BOARD ASSEMBLY

1.6.1 Precautions

1. Carefully handle the CCD image sensor, optical LPF, lens, etc. during the disassembly work. Pay the most careful attention to the surface of those parts not to get it soiled, scratched or dusty. If some of those surfaces gets soiled with fingerprints, etc., wipe it out with silicone paper, clean chamois, cleaning cloth or the like.
2. The new CCD image sensor is occasionally shipped from the factory as a protection seal is applied onto its transparent glass. If so, leave the protection seal as it is and remove it just before installing the CCD image sensor in the OP block assembly.

1.6.2 How to remove OP block assembly and CCD board assembly

1. Remove the spacer.
2. Unsolder at the fourteen points (SD1) and remove the CCD board assembly.
3. Remove the two screws (1, 2) and then remove the CCD base assembly.

Note⑬a: Carefully remove the CCD base assembly, because the space rubber and optical LPF may be removed together with the CCD image sensor.

Note⑬b: When replacing the CCD image sensor, don't replace it individually but replace the CCD base assembly in whole with a new one.

1.6.3 How to install ⑬ OP block assembly and CCD board assembly

1. Install the optical LPF with the ⑬ OP block assembly.
2. With the spacer rubber left attached to the CCD base assembly, install the assembly in the OP block assembly and clamp it using the two screws (1, 2).
3. Set the CCD board assembly in the CCD base assembly, and fasten it by soldering at the fourteen points (SD1).

1.6.4 Replacement of service parts

Service parts to be supplied for the OP block assembly are as follows.

When replacing a part, be very careful not to get the FPC wire broken or damaged by soldering (overheating).

1. Focus motor
2. Zoom motor
3. Iris motor unit

Note⑬c: When soldering the FPC wire of the focus motor or zoom motor during the replacement work, be sure to keep the tip of a soldering iron approximately 1 mm above the terminal.

Note⑬d: The iris motor unit includes one FPC assembly and two sensors.

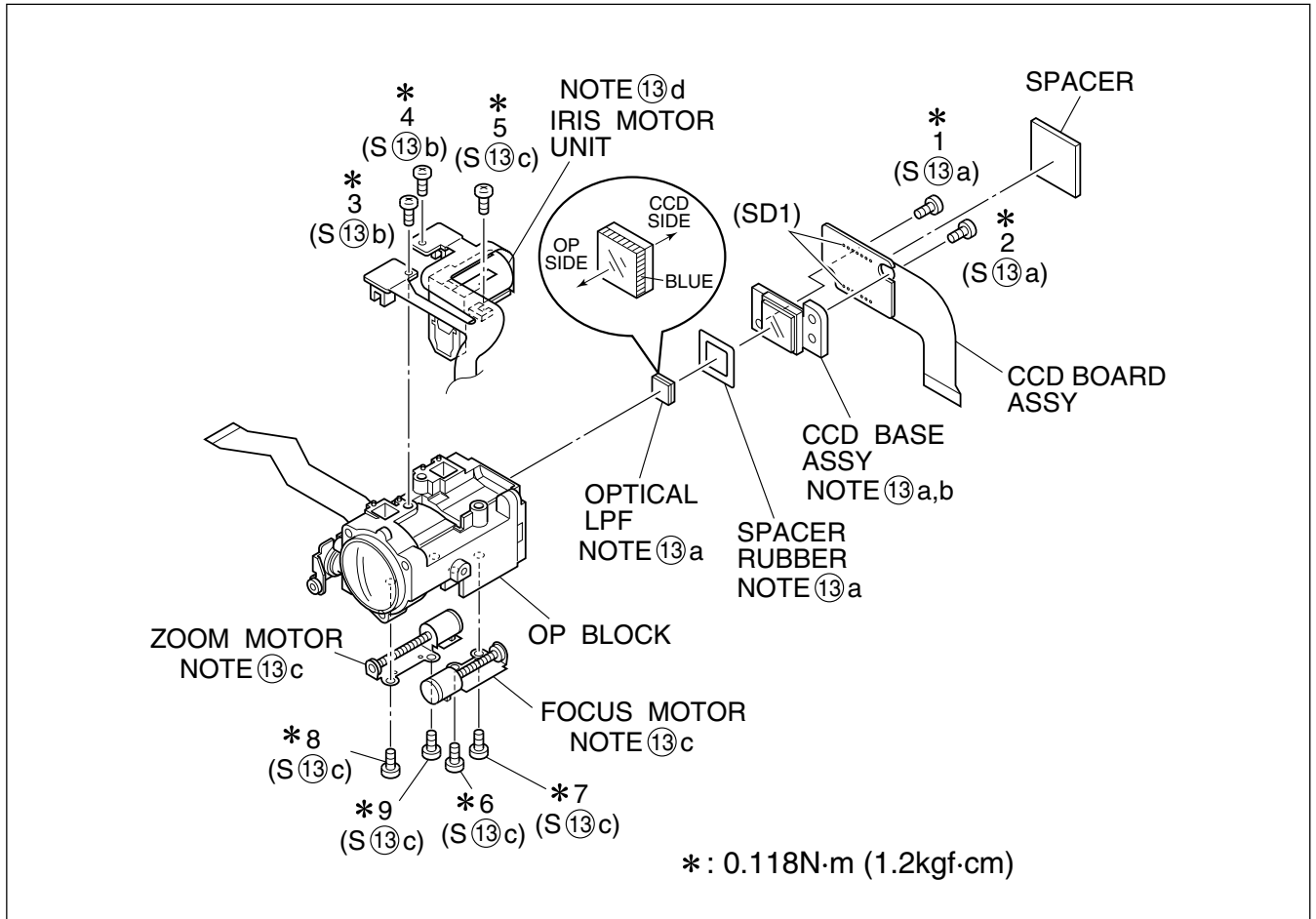


Fig. 1-6-1

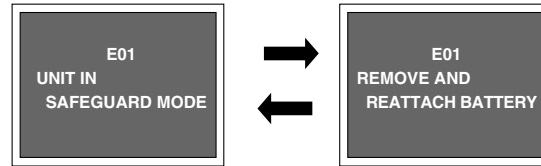
1.7 EMERGENCY DISPLAY

Whenever some abnormal signal is input to the syscon CPU, an error number (E01, as an example) is displayed on the LCD monitor or (in the electronic view finder).

In every error status, such the message as shown below alternately appear over and over.

- In an emergency mode, all operations except turning on/off the POWER switch are ineffectual.

Example (in case of the error number E01):



LCD display	Emergency mode	Details	Possible cause
E01	LOADING	In the case the encoder position is not shifted to the next point though the loading motor has rotated in the loading direction for 4 seconds or more. This error is defined as [E01].	<ol style="list-style-type: none"> The mechanism is locked during mode shift. The mechanism is locked at the mechanism loading end, because the encoder position is skipped during mechanism mode shift. No power is supplied to the loading MDA.
E02	UNLOADING	In the case the encoder position is not shifted to the next point though the loading motor has rotated in the unloading direction for 4 seconds or more. This error is defined as [E02].	<ol style="list-style-type: none"> The mechanism is locked during mode shift. The mechanism is locked at the mechanism loading end, because the encoder position is skipped during mechanism mode shift.
E03	TU & SUP REEL FG	In the case no REEL FG is produced for 4 seconds or more in the capstan rotation mode after loading was complete, the mechanism mode is shifted to STOP with the pinch roller set off. This error is defined as [E03]. However, no REEL EMG is detected in the SLOW/STILL mode.	<ol style="list-style-type: none"> The idler gear does not engage with the reel disk well. Though the idler gear and reel disk are engaged with each other, the tape is not wound because of overload to the mechanism. No FG pulse is output from the reel sensor. No power is supplied to the reel sensor. Tape transport operation takes place with a cassette having no tape inside. The tape slackens and no pulse is produced until the slack is taken up and the tape comes into the normal status.
E04	DRUM FG	In the case there is no DRUM FG input in the drum rotation mode for 4 seconds or more. This error is defined as [E04], and the mechanism mode is shifted to STOP with the pinch roller set off.	<ol style="list-style-type: none"> The drum cannot be started or drum rotation is stopped because tape transport load is too high. <ol style="list-style-type: none"> Tape tension is extremely high. The tape is damaged or soiled with grease, etc. The DRUM FG signal is not received by the syscon CPU. <ol style="list-style-type: none"> Disconnection in the middle of the signal line. Failure of the DRUM FG pulse generator (hall element). No drum control voltage is supplied to the MDA. No power is supplied to the DRUM MDA.
E05	—	—	—
E06	CAPSTAN FG	In the case no CAPSTAN FG is produced in the capstan rotation mode for 2 seconds or more. This error is defined as [E06], and the mechanism mode is shifted to STOP with the pinch roller set off. However, no CAPSTAN EMG is detected in the STILL/FF/REW mode.	<ol style="list-style-type: none"> The CAPSTAN FG signal is not received by the syscon CPU. <ol style="list-style-type: none"> Disconnection in the middle of the signal line. Failure of the CAPSTAN FG pulse generator (MR element). No capstan control voltage is supplied to the MDA. No power is supplied to the CAPSTAN MDA. The capstan cannot be started or capstan rotation is stopped because tape transport load is too high. <ol style="list-style-type: none"> Tape tension is extremely high. (Mechanical locking) The tape is damaged or soiled with grease, etc. (Tape tangling occurs, etc.)

(DVC_03)

Table 1-7-1

1.8 SERVICE KNOW-HOW

When performing disassembly/assembly work to this model, the parts that are most complicated and require special attention are the E.VF unit and the AUDIO board, OP block and shoe assemblies, all of which are mounted inside the lower case assembly.

Care should be taken in handling these parts as they are mounted inside the lower case assembly (except the E.VF unit) and there is a lack of adequate space to work conveniently. This section gives further details regarding the disassembly procedures, although they have been described in previous sections.

1. See Fig. 1-8-1.

- (1) Remove the hood by moving the ⑩ microphone out of way.
- (2) Peel off the spacer, remove the screw (32) and take out the ⑬ OP block assembly by moving the ⑩ microphone out of the way.
- (3) Remove the screw (33) and, while opening the ⑫ AUDIO board assembly, disconnect the wire from the connector (CN203) and remove the ⑩ microphone.
- (4) Remove the screw (34), peel off the spacer, take out the ⑪ E.VF assembly by moving the ⑭ shoe assembly out of way, disconnect the FPC from the connector (CN204).

Note ⑩,⑪: *Be careful not to damage the FPC or the switches when carrying out this work.*

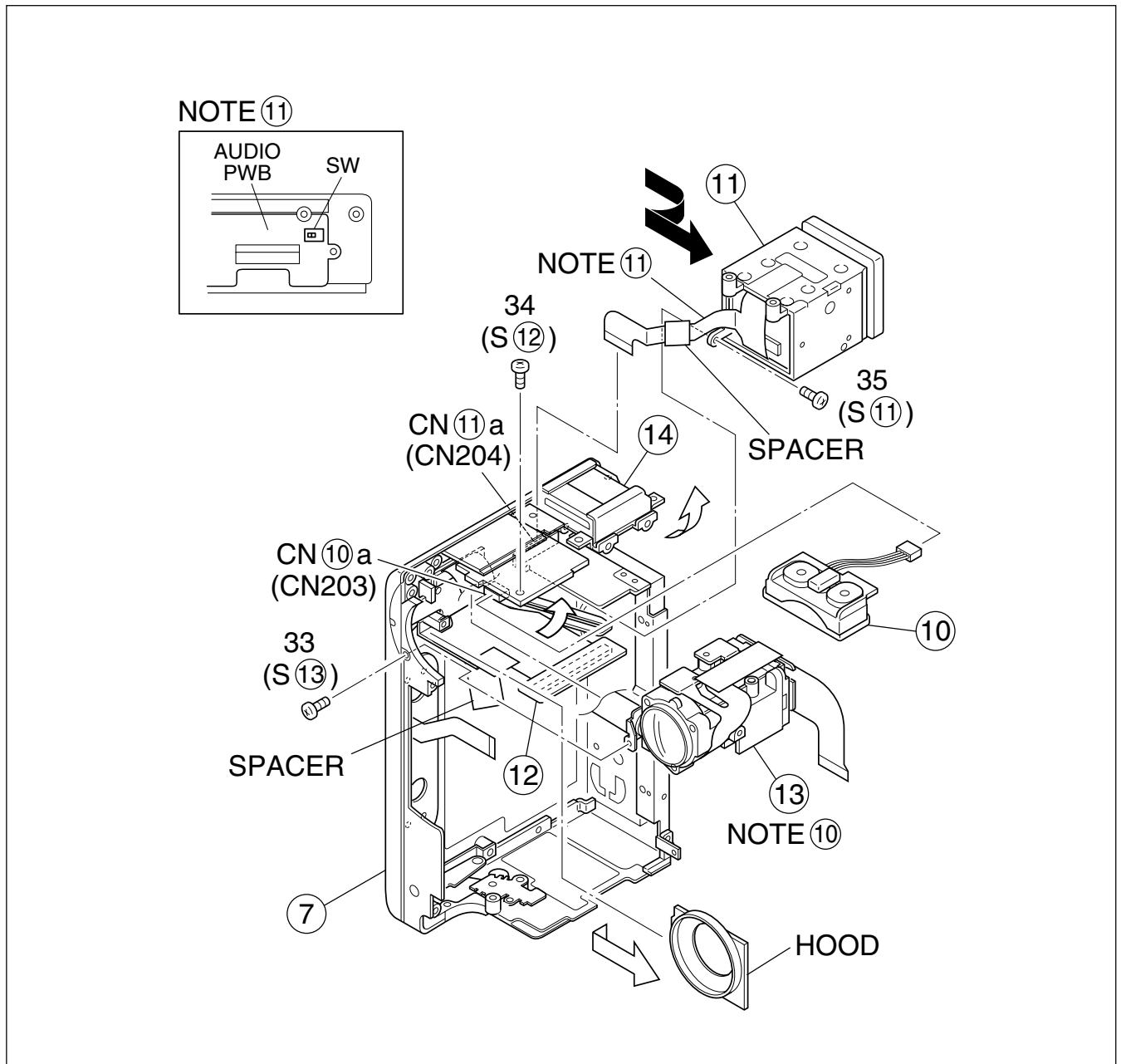


Fig. 1-8-1

2. See Fig. 1-8-2.

- (1) Remove the two screws (35,36) in order to free the ⑫ AUDIO board assembly.
- (2) Remove the three screws (37 to 39), peel off the spacer and take out the ⑫ AUDIO board assembly together with the ⑬ OP block assembly and the ⑭ shoe assembly.

Note^⑫: *Be careful not to lose the VIDEO and DSC knobs, which may slip out during the disassembly.*

- (3) Disconnect the FPCs from the connectors on the ⑬ OP block assembly and the ⑭ shoe assembly.

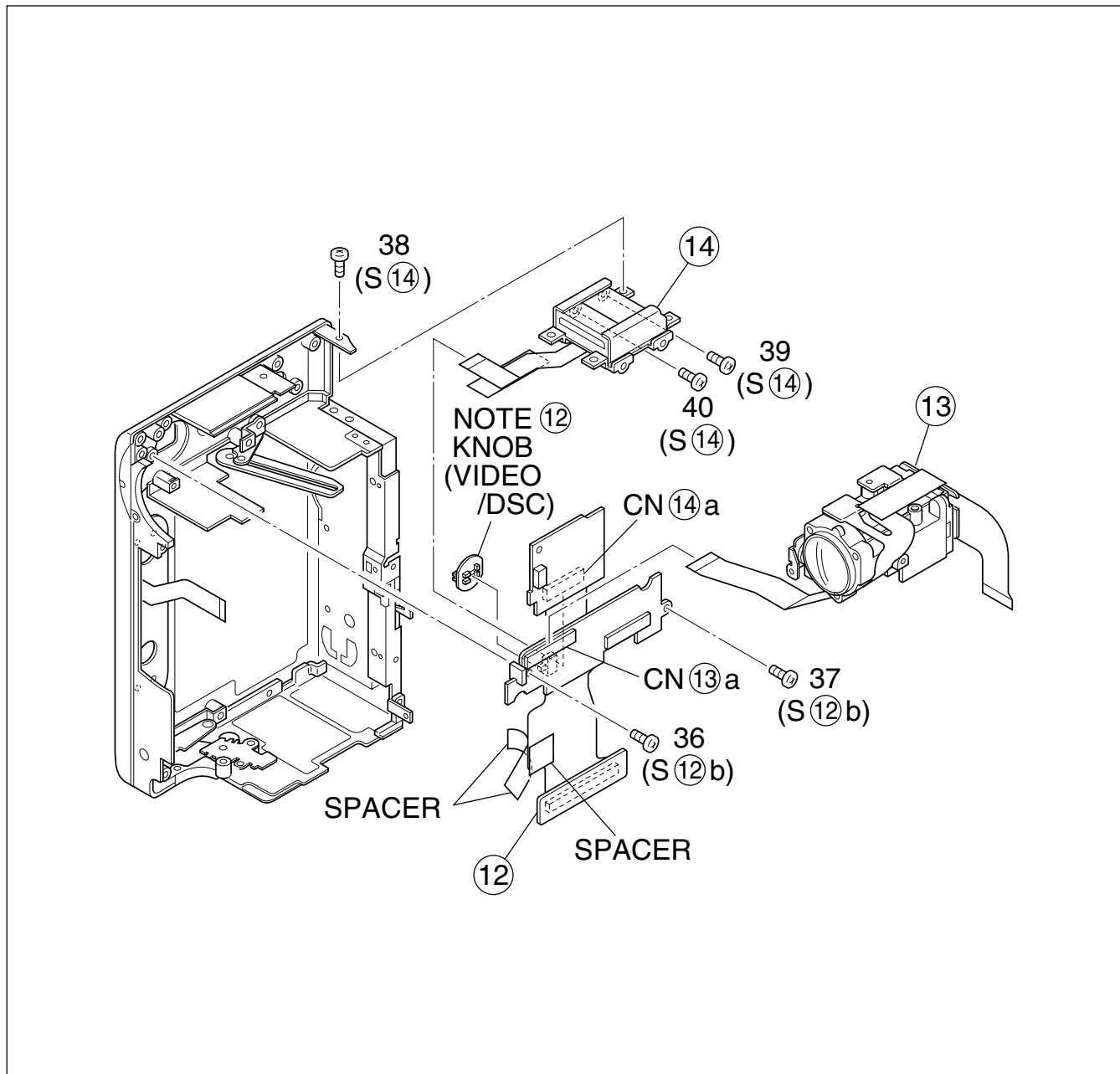


Fig. 1-8-2

1.9 SERVICE NOTE

Symbol No.	①	②	③	④	⑤
Removing order of screw	1	2	3	4	5
Place to stick screw					
Reference drawing	Fig.1-3-1	Fig.1-3-2	Fig.1-3-3a	Fig.1-3-3b	Fig.1-3-4
Screw tightening torque		I	I	II	I
					III

Symbol No.	⑥	⑦	⑧	⑨	⑩	⑪	⑫	⑬	⑭
Removing order of screw	22	23	24	25	26	27	28	29	30
Place to stick screw									
Reference drawing	Fig.1-3-5	Fig.1-3-6	Fig.1-3-7	Fig.1-3-8a	Fig.1-3-8b				
Screw tightening torque									

Removing order of screw	1	2	3	4	5
Place to stick screw	*	*	*	*	*
Reference drawing	Fig. 1-4-1				
Screw tightening torque	I				

Removing order of screw	1	2	3	4	5	6
Place to stick screw						
Reference drawing	Fig.1-5-1					
Screw tightening torque	IV					

Removing order of screw	1	2	3	4	5	6	7	8	9
Place to stick screw									
Reference drawing	Fig.1-6-1								
Screw tightening torque	II								

< NOTE >

- 1) *: Don't reuse the screw, because screw lock bond was applied to them.
- 2) Pay careful attention to tightening torque for each screw.
 I : 0.078N·m (0.8kgf·cm) II : 0.118N·m (1.2kgf·cm) III : 0.098N·m (1.0kgf·cm)
 IV : 0.069N·m (0.7kgf·cm)

SECTION 2 MECHANISM ADJUSTMENT

2.1 PRELIMINARY REMARKS ON ADJUSTMENT AND REPAIR

2.1.1 Precautions

1. When fastening parts, pay careful attention to the tightening torque of each screw. Unless otherwise specified, tighten a screw with the torque of 0.039 N·m (0.4 kgf·cm).
2. Be sure to disconnect the set from the power supply before fastening and soldering parts.
3. When disconnecting/connecting wires, be careful not to get them and their connectors damaged. (Refer to the Section 1.)
4. When replacing parts, be very careful neither to damage other parts nor to fit wrong parts by mistake.

2.1.2 Notes on procedure for disassembly/assembly

The disassembling procedure table (Table 2-4-1 on page 2-5, a part of the table is shown below for reference) shows the procedure to disassemble/reassemble mechanism parts.

Carefully read the following explanation before starting actual disassembling/reassembling work. The item numbers (circled numbers) in the following explanation correspond to those appearing under respective columns of the table.

- (1) Circled numbers appearing in this column indicate the order to remove parts. When reassembling, follow these numbers in the reverse order. Circled numbers in this column correspond to those appearing in drawings of this section.
- (2) This column shows part names corresponding to circled numbers in the left column.
- (3) The symbol (T or B) appearing in this column shows the side which the objective part is mounted on.
T = the upper side, B = the lower side
- (4) Symbols appearing in this column indicate drawing numbers.
Step Part Name Fig. Point Note Remarks

- (5) This column indicates parts and points such as screws, washers, springs, and others to be removed/fitted for disassembling/reassembling the mechanism. Besides such the parts, this column occasionally indicates working points.

P = Spring
W = Washer
S = Screw
* = Lock (L), soldering (SD), shield, connector (CN), etc.

- Example
- Remove ((W1)=Washer W1.
 - **Remove the solder at (SD1)=Point SD1.
 - **Disconnect (A)=Connector (A).
- (6) Numbers in this column represent the numbers of notes in the text.
(For parts that need phase adjustment after reassembling, refer to "2.6 MECHANISM ADJUSTMENTS".)
 - (7) This column indicates required after-disassembling/reassembling work such as phase adjustment or mechanism adjustment.

NO.	PART NAME		FIG.	POINT	NOTE	REMARKS
①	CASSETTE HOUSING ASSY	T	Fig.2-4-3	3(S①),(L①a)-(L①e)	NOTE①a,b,c,d	ADJUSTMENT
②	UPPER BASE ASSY	T	Fig.2-4-4	(S②),(L②a),(L②b)	NOTE②	
③	DRUM ASSY	T		(S③a),2(S③b)	NOTE③a,b	
④	REEL DISK ASSY(SUP)	T	Fig.2-4-5	(W④)	NOTE④a	
⑤	REEL DISK ASSY(TU)	T		(W⑤)	NOTE⑤	
⑥	REEL COVER ASSY	T		2(W⑥),2(S⑥a),(S⑥b)	NOTE⑥	ADJUSTMENT

↑
↑
↑
↑
↑
↑
↑

(1)
(2)
(3)
(4)
(5)
(6)
(7)

2.2 JIGS AND TOOLS REQUIRED FOR DISASSEMBLY, ASSEMBLY AND ADJUSTMENT

2.2.1 Tools required for adjustments

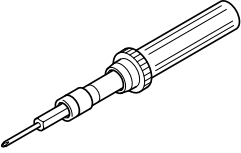
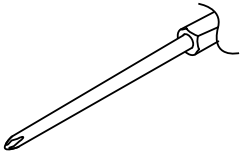
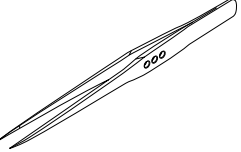
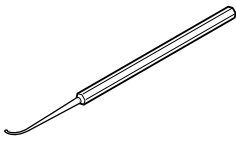
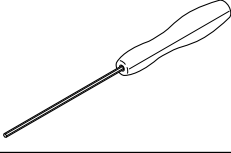
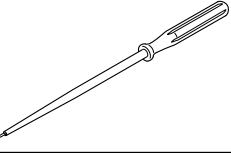
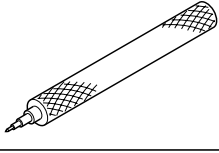
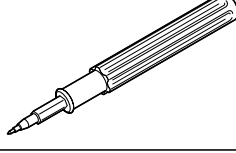
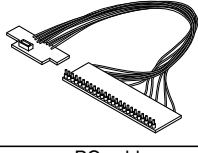
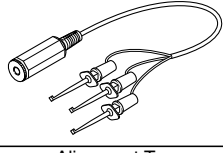
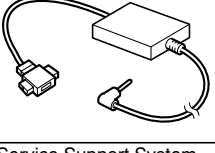
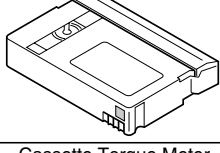

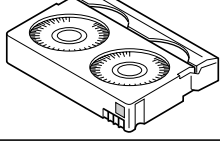
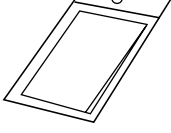
1	Torque Driver YTU94088	2	Bit YTU94088-003
			
3	Tweezers P-895	4	Chip IC Replacement Jig PTS40844-2
			
5	Guide Driver (Hexagonal) D-770-1.27	6	Adjustment Driver YTU94028
			
7	Slit Washer Installation Jig YTU94121A	8	Slit Washer Installation Jig YTU94121B
			
9	Jig Connector cable YTU93106C	10	Communication cable YTU93107A
			
11	PC cable QAM0099-002	12	Alignment Tape MC-2
			
13	Service Support System YTU94057-54	14	Cassette Torque Meter YTU94151A
			
15	Cleaning Cloth KSMM-01		
			

Table 2-2-1

1. Torque Driver

Be sure to use to fastening the mechanism and exterior parts because those parts must strictly be controlled for tightening torque.

2. Bit

This bit is slightly longer than those set in conventional torque drivers.

3. Tweezers

To be used for removing and installing parts and wires.

4. Chip IC Replacement Jig

To be used for adjustment of the camera system.

5. Guide Driver (Hexagonal)

To be used to turn the guide roller to adjustment of the linearity of playback envelope.

6. Adjustment Driver

To be used for adjustment.

7. Slit Washer Installation Jig

To be used to install slit washers.

8. Slit Washer Installation Jig (NEW TYPE)

To be used to install slit washers.

9. Jig Connector Cable

Connected to CN114 of the main board and used for electrical adjustment, etc.

10. Communication Cable

Connect the Communication cable between the PC cable and Jig connector cable when performing a PC adjustment.

11. PC Cable

To be used to connect the VideoMovie and a personal computer with each other when a personal computer is used for adjustment.

12. Alignment Tape

To be used for check and adjustment of interchangeability of the mechanism.

13. Service Support System

To be used for adjustment with a personal computer.

14. Cassette Torque Meter

This is used to check the back tension and play torque during mechanism adjustment.

Note: When using the cassette torque meter, install the service support system software in advance.

- LED : Forced to ON
- EJECT SW : OFF (Cancel)

The above setting is required to prevent any tape damage that may occur because the cassette torque meter cannot detect the leading/trailing sections of the tape.

15. Cleaning Cloth

Recommended cleaning cloth to wipe down the video heads, mechanism (tape transport system), optical lens surface.

2.3 DISASSEMBLY/ASSEMBLY OF MECHANISM ASSEMBLY

2.3.1 General statement

The mechanism should generally be disassembled/assembled in the C.IN mode (ASSEMBLY mode). (Refer to Fig. 2-3-1,2.)

However, when the mechanism is removed from the main body, it is set in the STOP mode. Therefore, after the mechanism is removed from the main body, supply 3 V DC to the electrode on the top of the loading motor to enter the mechanism mode into the C IN mode compulsory.

<Mechanism assembly/Cassette housing assembly>

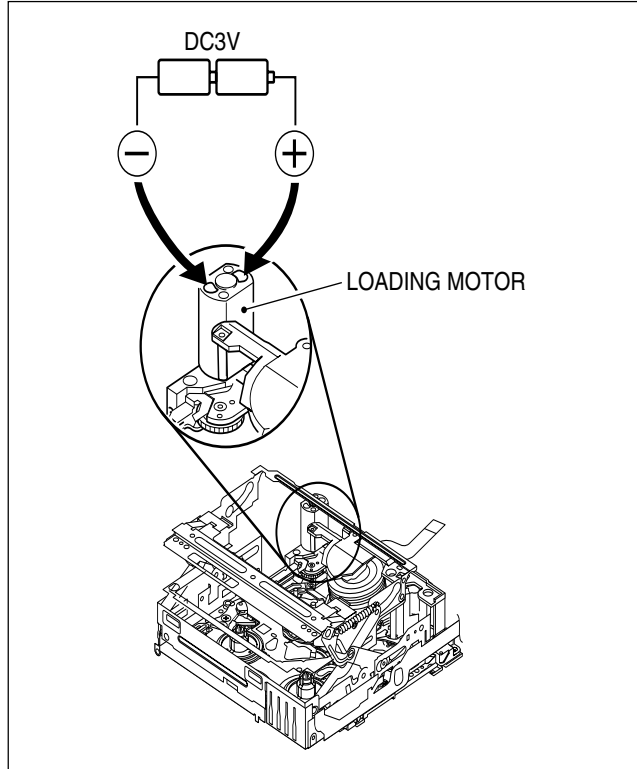


Fig. 2-3-1

<Back side of the mechanism assembly>

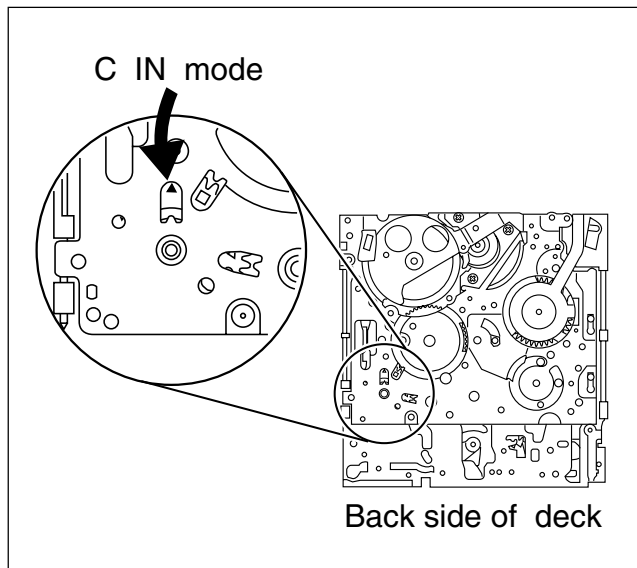


Fig. 2-3-2

2.3.2 Explanation of mechanism mode

The mechanism mode of this model is classified into five modes as shown in Table 2-3-1. Each mechanism mode can be distinguished from others by the relative position of "△", "○", "◻" marks on the sub cam gear to the inner or outer protrusion on the main deck. Refer to Fig. 2-3-3 to 2-3-8 below.

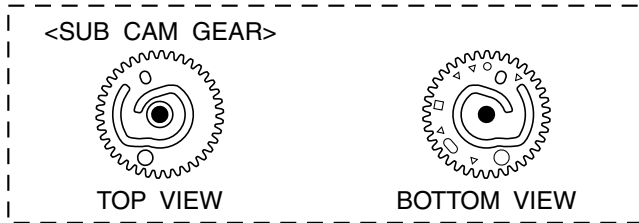


Fig. 2-3-3

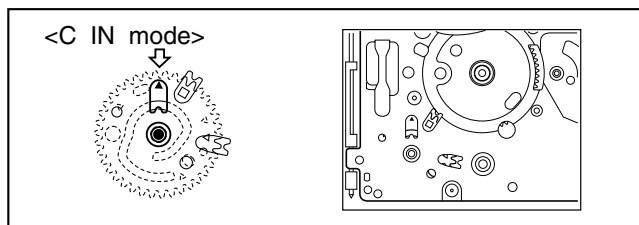


Fig. 2-3-4

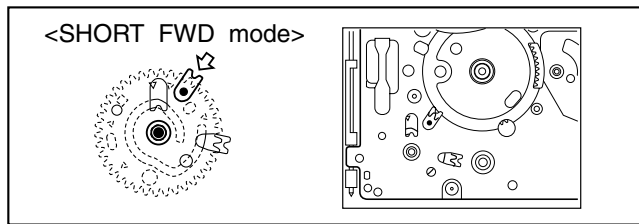


Fig. 2-3-5

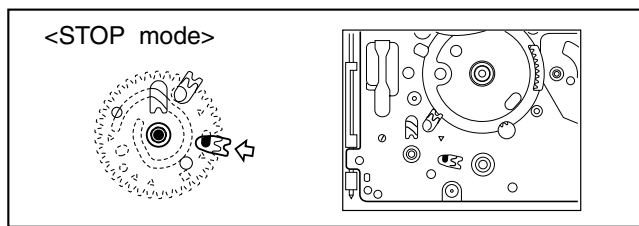


Fig. 2-3-6

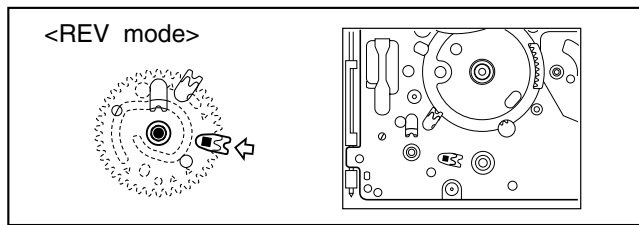


Fig. 2-3-7

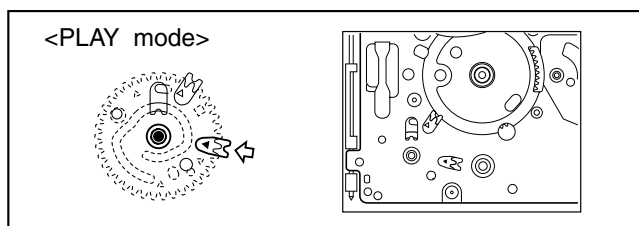


Fig. 2-3-8

2.3.3 Mechanism timing chart

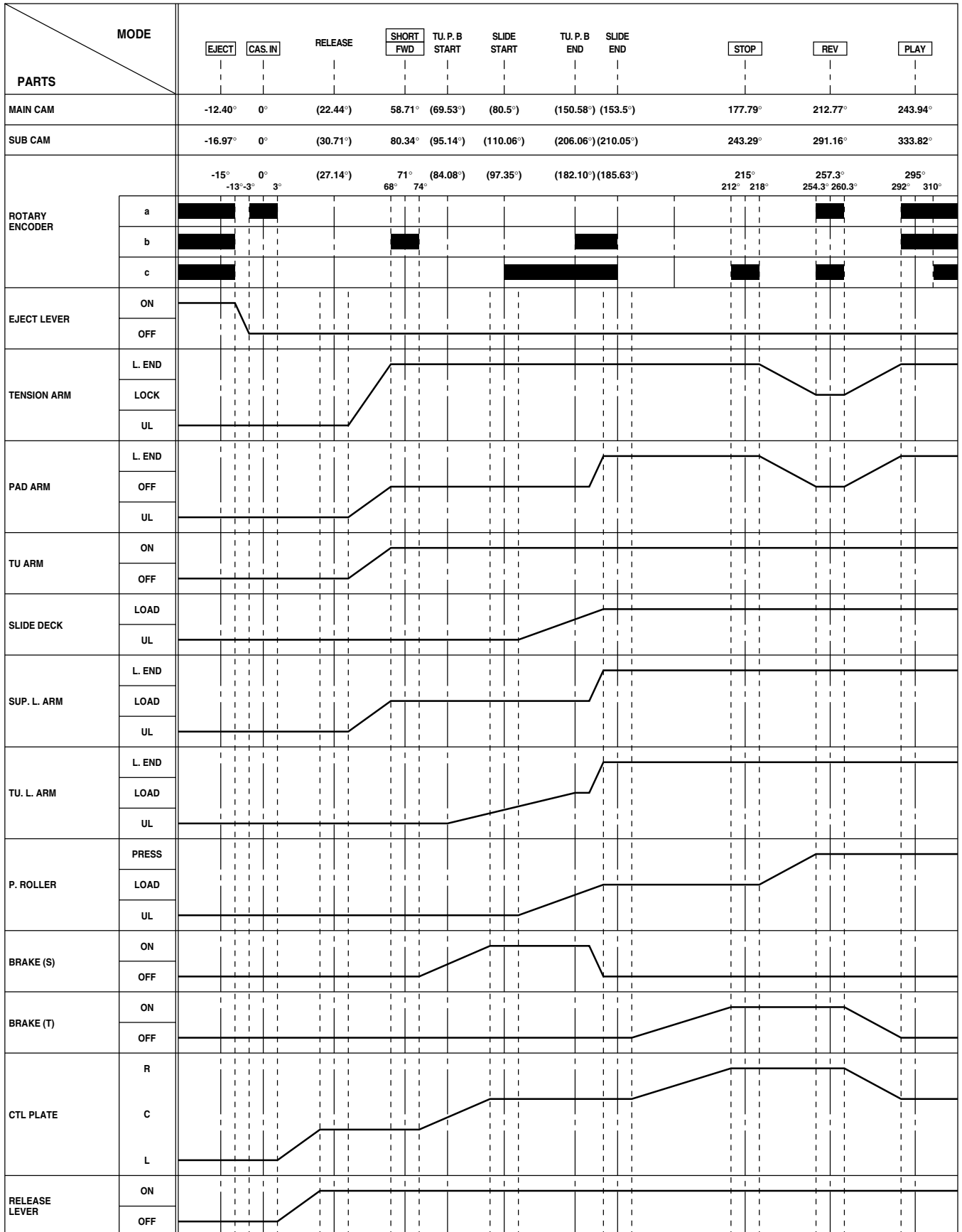


Table 2-3-1

2.4 DISASSEMBLING PROCEDURE TABLE

MARK: ★ After assembly, perform adjustments.

NO.	PART NAME		FIG.	POINT	NOTE	REMARKS
①	CASSETTE HOUSING ASSY	T	Fig.2-4-3	3(S①),(L①a)-(L①e)	NOTE①a,b,c,d	ADJUSTMENT
②	UPPER BASE ASSY	T	Fig.2-4-4	(S②),(L②a),(L②b)	NOTE②	
③	DRUM ASSY	T		(S③a),2(S③b)	NOTE③a,b	
④	REEL DISK ASSY(SUP)	T	Fig.2-4-5	(W④)	NOTE④	
⑤	REEL DISK ASSY(TU)	T		(W⑤)	NOTE⑤	
⑥	REEL COVER ASSY	T		2(W⑥),2(S⑥a),(S⑥b)	NOTE⑥	ADJUSTMENT
⑦	TENSION ARM ASSY	T	Fig.2-4-6	—	NOTE⑦	ADJUSTMENT / ★
⑧	SLANT POLE ARM ASSY	T		(P⑧)	NOTE⑧	ADJUSTMENT
⑨	TU ARM ASSY	T		—	NOTE⑨	ADJUSTMENT
⑩	SWING ARM ASSY	T		(S⑩)	NOTE⑩	ADJUSTMENT
⑪	SLIDE DECK ASSY	T	Fig.2-4-7a	2(S⑪a),(S⑪b),2(L⑪a), 2(L⑪b),(L⑪c)	NOTE⑪a,b	ADJUSTMENT / ★
⑫	PAD ARM ASSY	T	Fig.2-4-7b	(P⑫),(L⑫),(W⑫)	NOTE⑫	ADJUSTMENT / ★
⑬	SUP BRAKE ASSY	T		(P⑬),(L⑬),(S⑬)	NOTE⑬	ADJUSTMENT
⑭	TU BRAKE ASSY	T		(P⑭),(L⑭),(W⑭)	NOTE⑭	ADJUSTMENT
⑮	TENSION CTL LEVER ASSY	T	Fig.2-4-8	(W⑮)	NOTE⑮	ADJUSTMENT
⑯	CENTER GEAR	T		—	NOTE⑯	
⑰	PINCH ROLLER ARM F. ASSY	T		(W⑰)	NOTE⑰	
⑱	TENSION CTL PLATE ASSY	T		—	NOTE⑱	ADJUSTMENT
⑲	BRAKE CTL LEVER ASSY	T		—	NOTE⑲	ADJUSTMENT
⑳	MOTOR BRACKET ASSY	T		Fig.2-4-9	3(S⑳),(L⑳a),2(L⑳b)	NOTE⑳
㉑	GUIDE RAIL ASSY	T	2(W㉑),(S㉑),2(L㉑a),(L㉑b)		NOTE㉑	ADJUSTMENT
㉒	SLIDE LEVER 2 ASSY	T	—		NOTE㉒	ADJUSTMENT / ★
㉓	LOADING PLATE ASSY	T	(W㉓)		NOTE㉓	ADJUSTMENT
㉔	MODE GEAR	T	—		NOTE㉔	
㉕	EJECT LEVER	T	(W㉕)		NOTE㉕	ADJUSTMENT
㉖	BASE R ASSY	T	Fig.2-4-10		(S㉖a),(S㉖b),2(L㉖)	NOTE㉖
㉗	ROTARY ENCODER	T		2(S㉗)	NOTE㉗	PHASE ADJUSTMENT
㉘	GEAR COVER ASSY	T		(S㉘a),2(S㉘b)	—	
㉙	MAIN CAM ASSY	T		—	NOTE㉙	PHASE ADJUSTMENT
㉚	SLIDE ARM ASSY	T	Fig.2-4-11	—	NOTE㉚	ADJUSTMENT
㉛	CONNECT GEAR 2	T		—	NOTE㉛	
㉜	SUB CAM ASSY	T		(S㉜)	NOTE㉜	PHASE ADJUSTMENT
㉝	CONTROL ARM ASSY	T		—	NOTE㉝	ADJUSTMENT
㉞	REEL GEAR 1	T		—	NOTE㉞	
㉟ / ㊱	DRUM BASE ASSY/ CAPSTAN MOTOR	T		Fig.2-4-12	3(S㉟)	NOTE㉟a,b
㊱	CAPSTAN MOTOR	T	(S㊱)		NOTE㊱	ADJUSTMENT
㊲	MAIN DECK ASSY	T	—		—	

Table 2-4-1

< TOP VIEW >

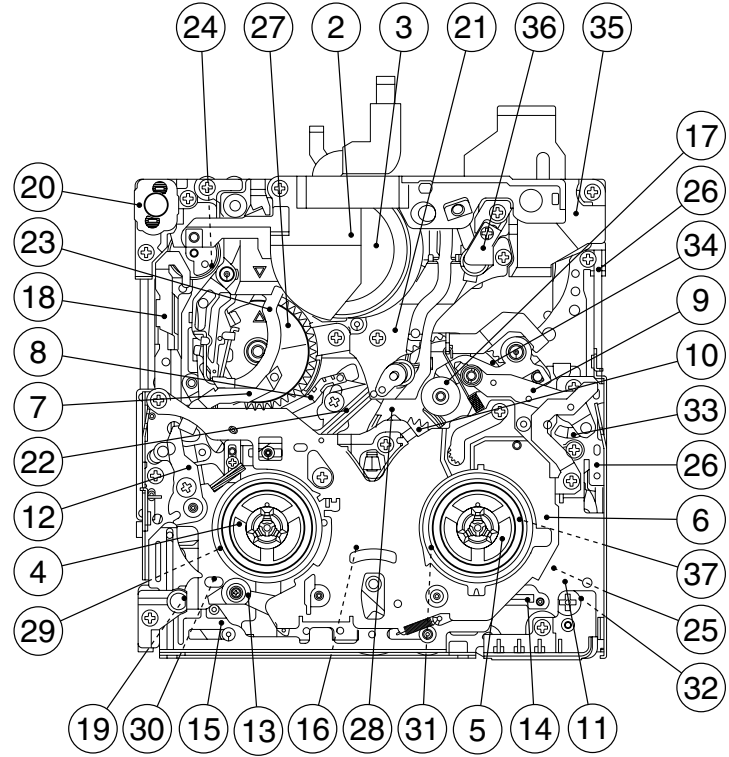


Fig. 2-4-1

< BOTTOM VIEW >

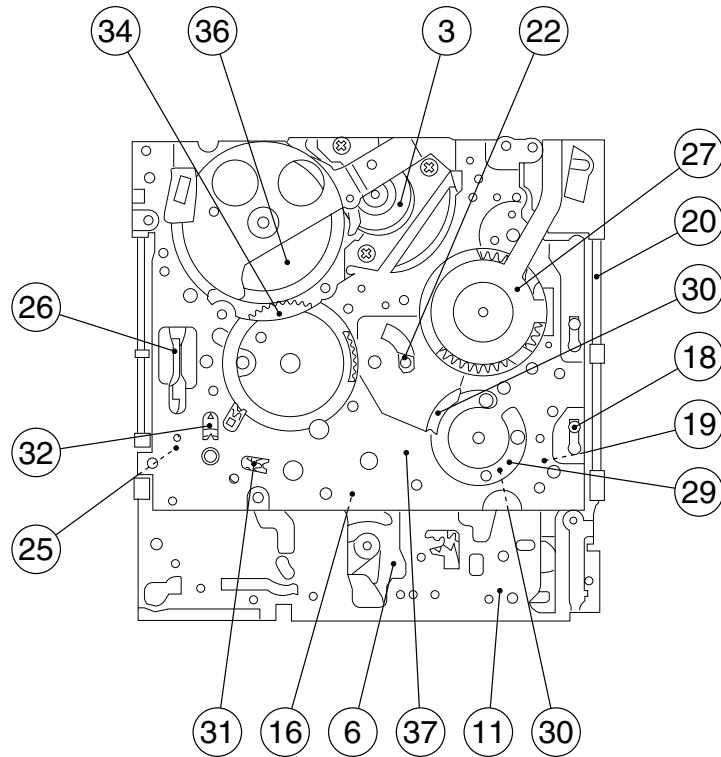


Fig. 2-4-2

2.4.1 Disassembly/assembly

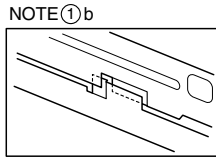
1. ① CASSETTE HOUSING ASSY

NOTE①a:

Be careful not to damage any of the parts during work.

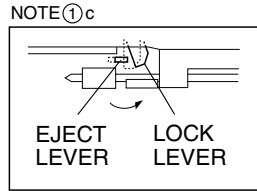
NOTE①b:

Special care is required in mounting.



NOTE①c:

When mounting, the CASSETTE HOUSING ASSY should be attached in the Eject status. Pay heed to the positions of the LOCK LEVER and EJECT LEVER during mounting.



NOTE①d:

When mounting, be sure to locate the FPC in the gap.

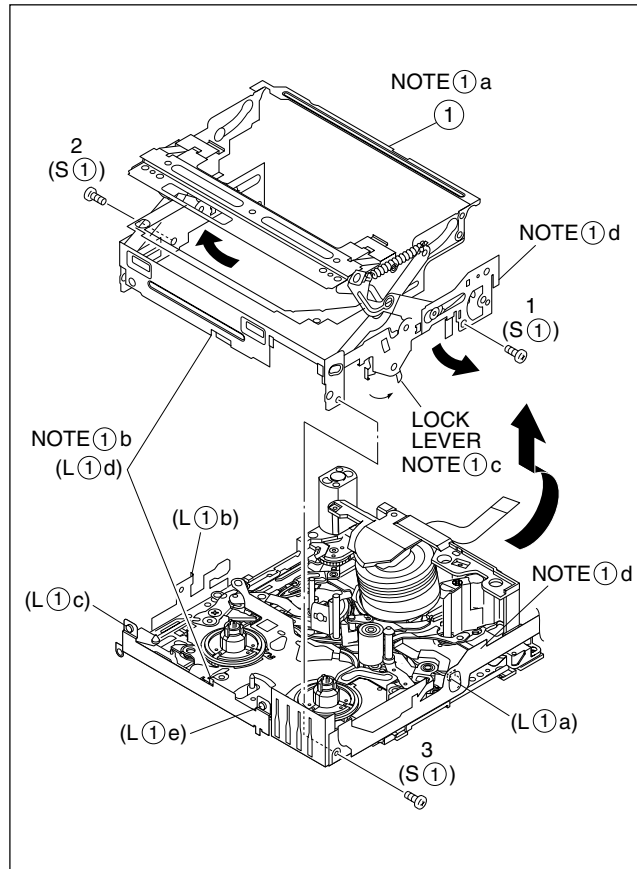
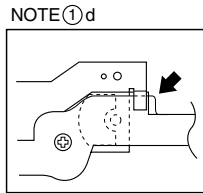


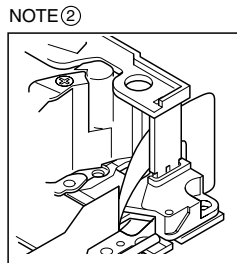
Fig. 2-4-3

2. ② UPPER BASE ASSY

③ DRUM ASSY

NOTE②:

When mounting, be sure to insert the FPC reinforcing sheet.



NOTE③a:

Be mindful of scratches or damage during work.

NOTE③b:

Be careful not to attach screws incorrectly.

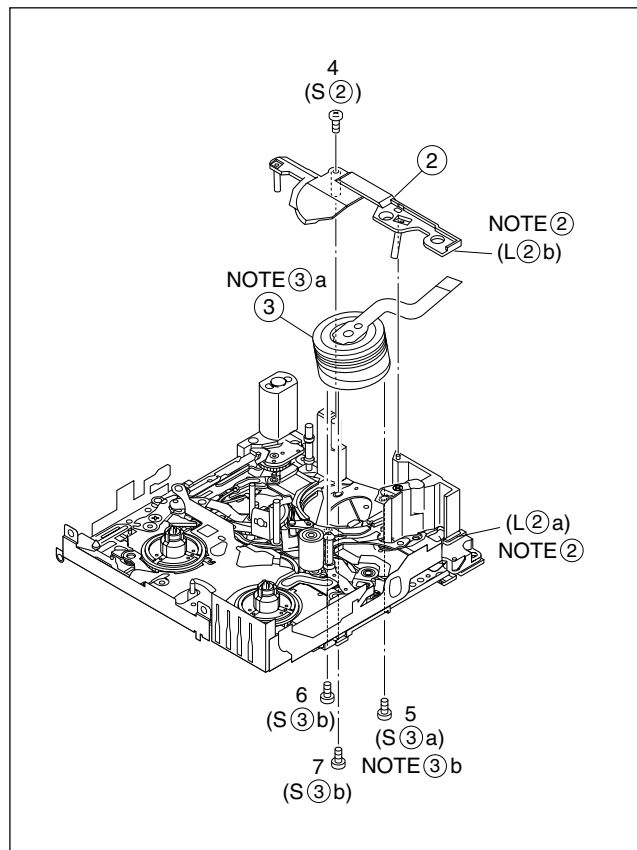
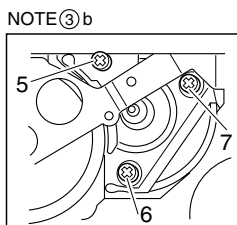


Fig. 2-4-4

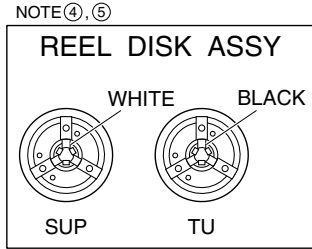
- 3. ④ REEL DISK ASSY(SUP)
- ⑤ REEL DISK ASSY(TU)
- ⑥ REEL COVER ASSY

NOTE④:

Be careful not to attach the REEL DISK wrongly. The Supply side can be identified by the white color at the center.

NOTE⑤:

Be careful not to attach the REEL DISK wrongly. The Take-up side can be identified by the black color at the center.



NOTE⑥:

Perform the following steps for mounting.

1. Align the 2 holes with the pins.
2. Attach the PINCH ROLLER ARM ASSY by aligning the positions.
3. Attach the SUB DECK ASSY by aligning the positions.
4. Check that the parts below them are located in the correct positions.
5. Tighten the 2 screws.
6. Tighten the screw.
7. Attach the 2 SLIT WASHER parts.

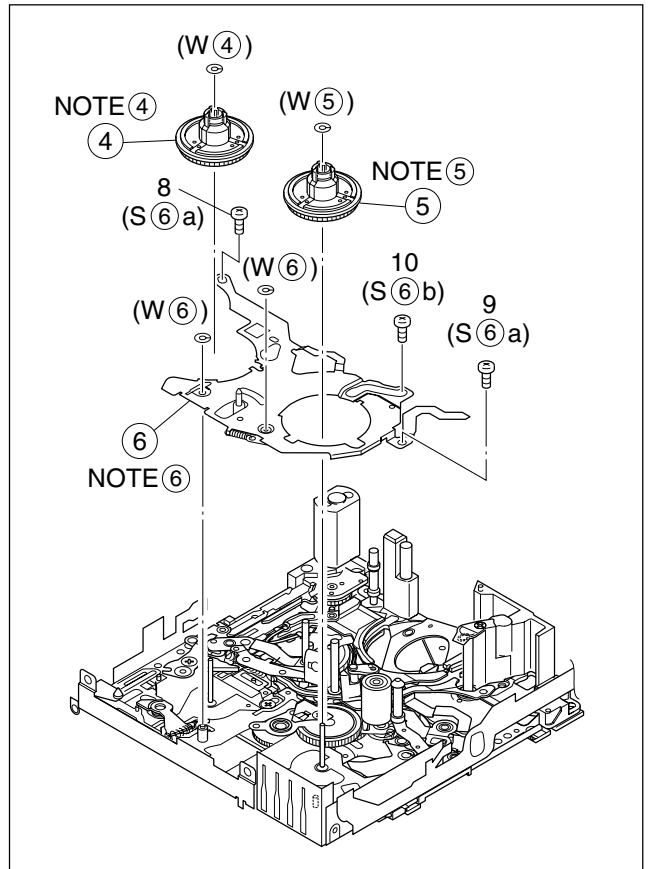
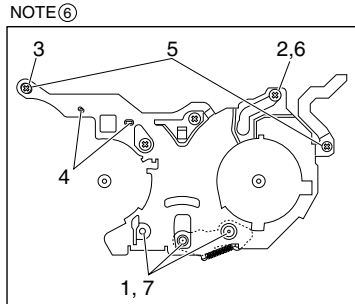
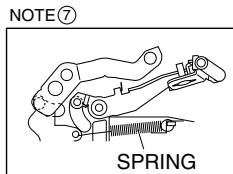


Fig. 2-4-5

- 4. ⑦ TENSION ARM ASSY
- ⑧ SLANT POLE ARM ASSY
- ⑨ TU ARM ASSY
- ⑩ SWING ARM ASSY

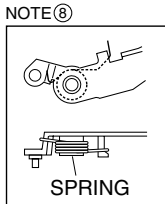
NOTE⑦:

When detaching, remove the spring of the ⑫ PAD ARM ASSY in advance. Pay attention to the attachment position.



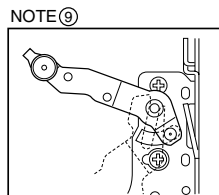
NOTE⑧:

Be careful not to lose any parts (such as a spring).



NOTE⑨:

Pay attention to the mounting position.



NOTE⑩:

When detaching, remove the screw then remove the SWING ARM ASSY by pulling it up and turning it.

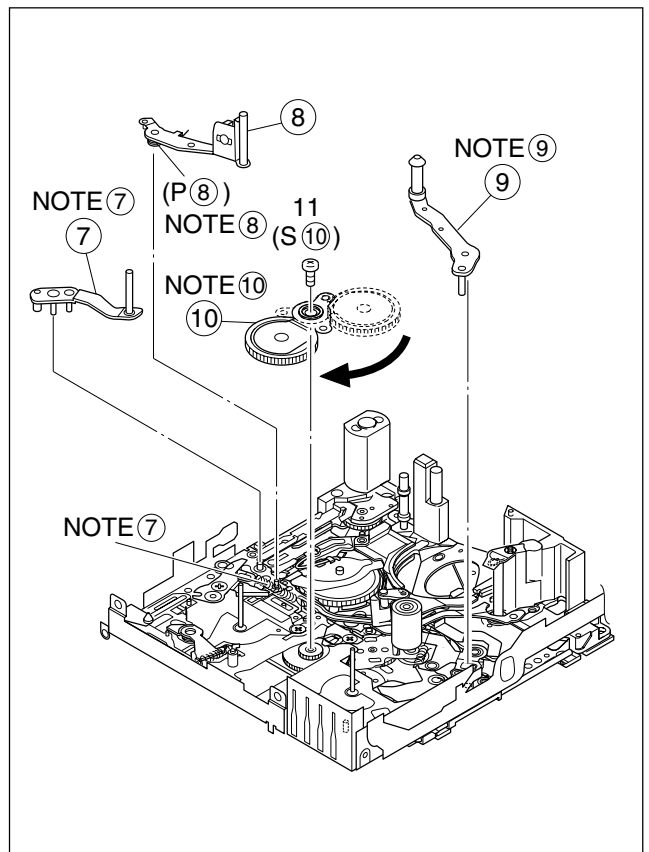
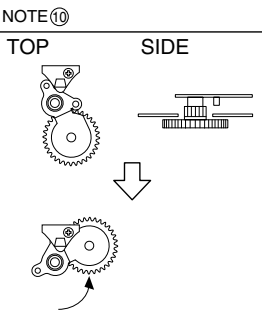


Fig. 2-4-6

5. ⑪ SLIDE DECK ASSY

NOTE⑪a:

Each of the parts on the SLIDE DECK ASSY can be replaced separately.
When detaching the assembly, if there is no need to replace any of its parts, remove the SLIDE DECK ASSY as it is.

NOTE⑪b:

When mounting, pay attention to the positions of the ⑫ SLIDE LEVER (2) studs and the ⑲ BRAKE CONTROL LEVER ASSY.
When mounting, position the CONTROL PLATE on the left side.
Pay attention to the position of the SLIDE GUIDE PLATE during mounting.

NOTE⑪b

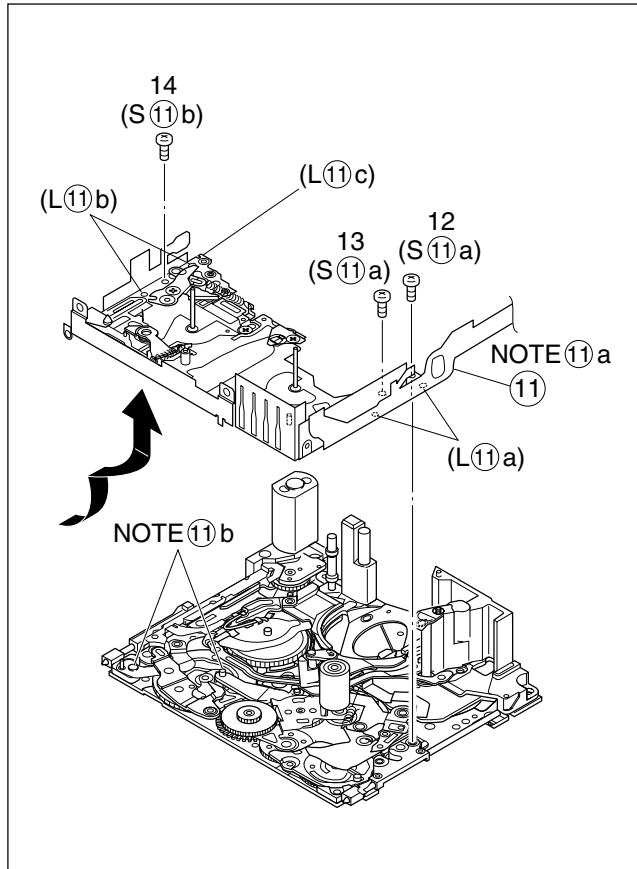
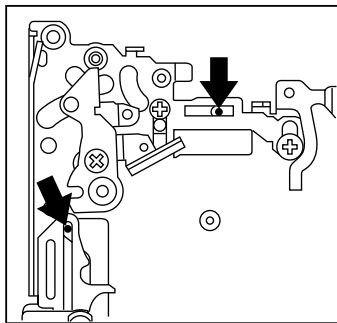


Fig. 2-4-7a

6. ⑫ PAD ARM ASSY
⑬ SUP BRAKE ASSY
⑭ TU BRAKE ASSY

NOTE⑫:

The spring may have already been disengaged when the ⑧ SLANT POLE ARM ASSY was removed.

NOTES⑬/⑭:

When mounting, pay attention to the correct positioning.
Mount the CONTROL PLATE by moving it fully toward the left side.

NOTE⑫ ⑬ ⑭

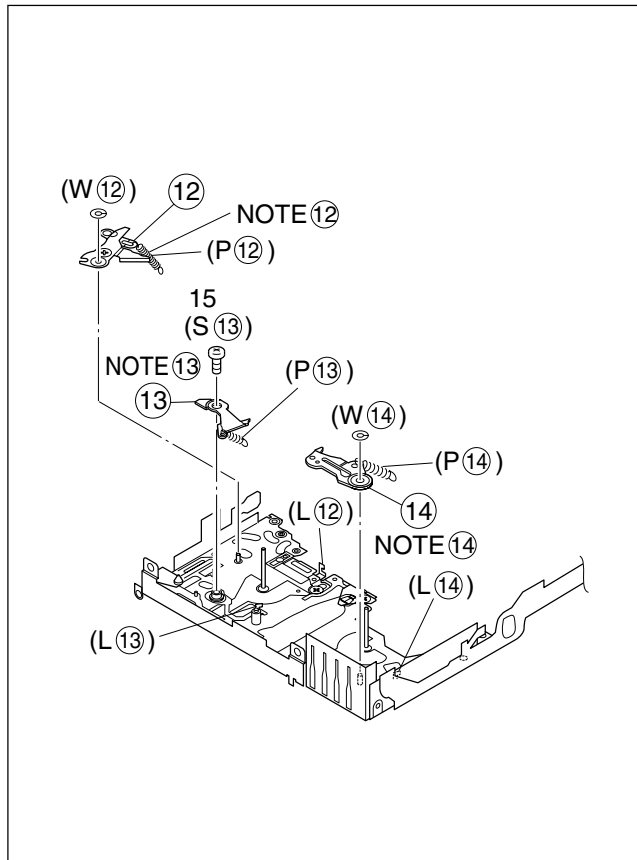
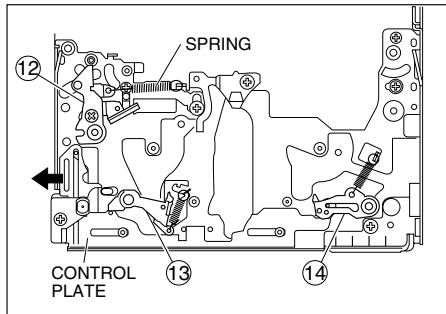
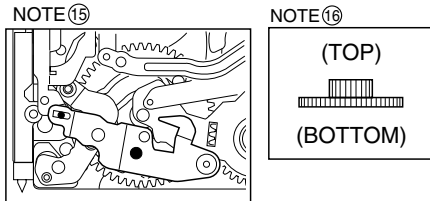


Fig. 2-4-7b

- 7. ⑮ TENSION CTL LEVER ASSY
- ⑯ CENTER GEAR
- ⑰ PINCH ROLLER ARM F. ASSY
- ⑱ TENSION CTL PLATE ASSY
- ⑲ BRAKE CTL LEVER ASSY

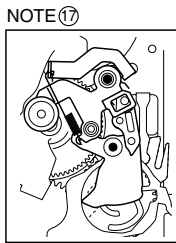
NOTES⑮/⑯:

When mounting, pay attention to the correct positioning.



NOTE⑰:

Take care against grease attachment during work.



NOTES⑱/⑲:

When mounting, pay attention to the correct positioning.

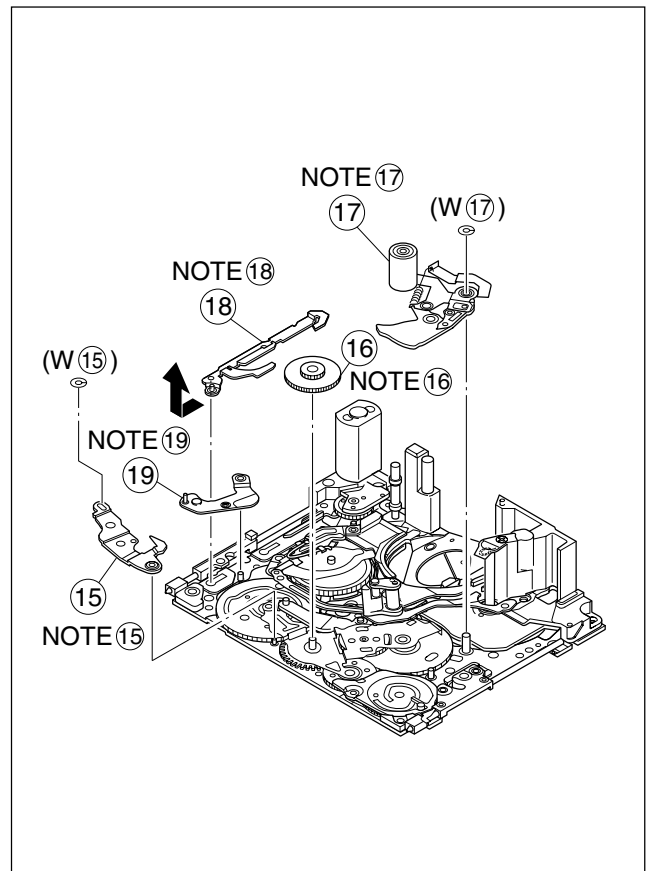
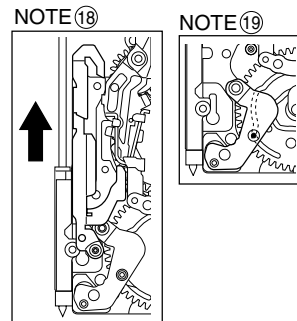
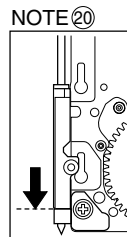


Fig. 2-4-8

- 8. ⑳ MOTOR BRACKET ASSY
- ㉑ GUIDE RAIL ASSY
- ㉒ SLIDE LEVER 2 ASSY
- ㉓ LOADING PLATE ASSY
- ㉔ MODE GEAR
- ㉕ EJECT LEVER

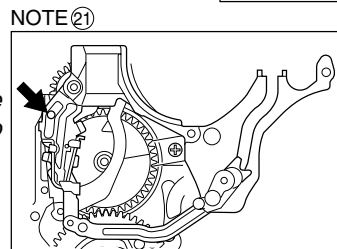
NOTE㉑:

When mounting, pay attention to the positioning of the sliding parts.



NOTE㉒:

When mounting, take care that no part is allowed to float or rattle.



NOTES㉓/㉔/㉕:

When mounting, pay attention to the correct positioning.

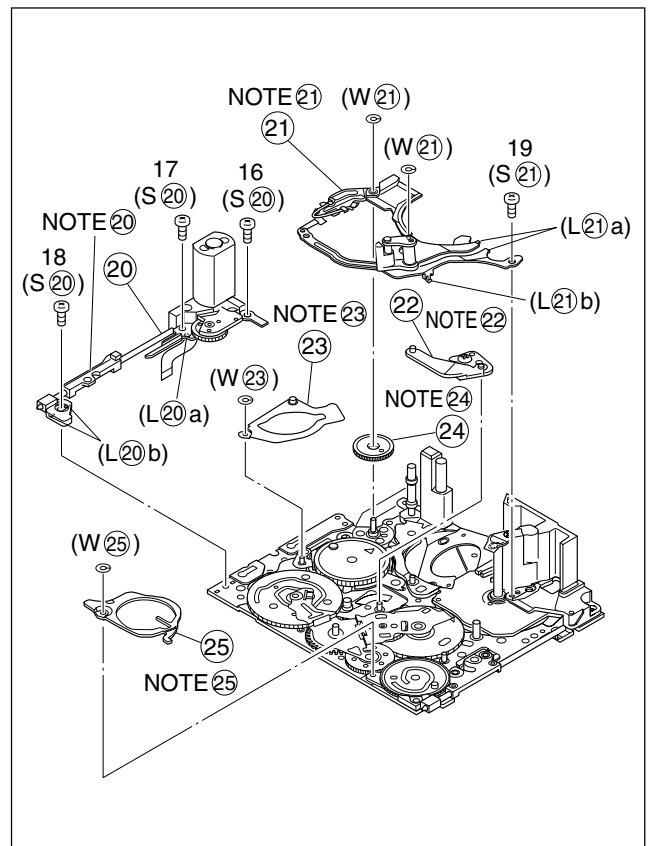
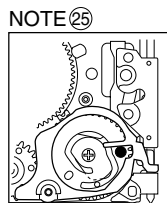
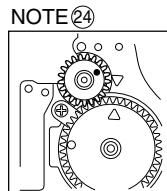
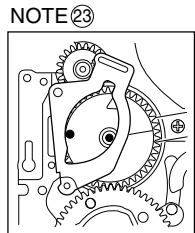
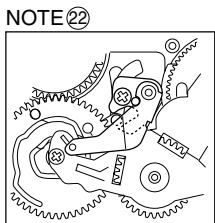


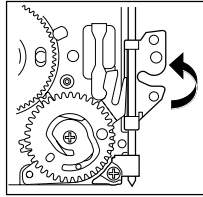
Fig. 2-4-9

- 9. 26 BASE R ASSY
- 27 ROTARY ENCODER
- 28 GEAR COVER ASSY
- 29 MAIN CAM ASSY

NOTE 26:

When mounting, fold the sliding part to the inner side.

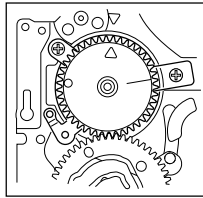
NOTE 26



NOTE 27:

When mounting, pay attention to the correct positioning and the FPC layout.

NOTE 27



NOTE 29:

When mounting, pay attention to the correct positioning.

NOTE 29

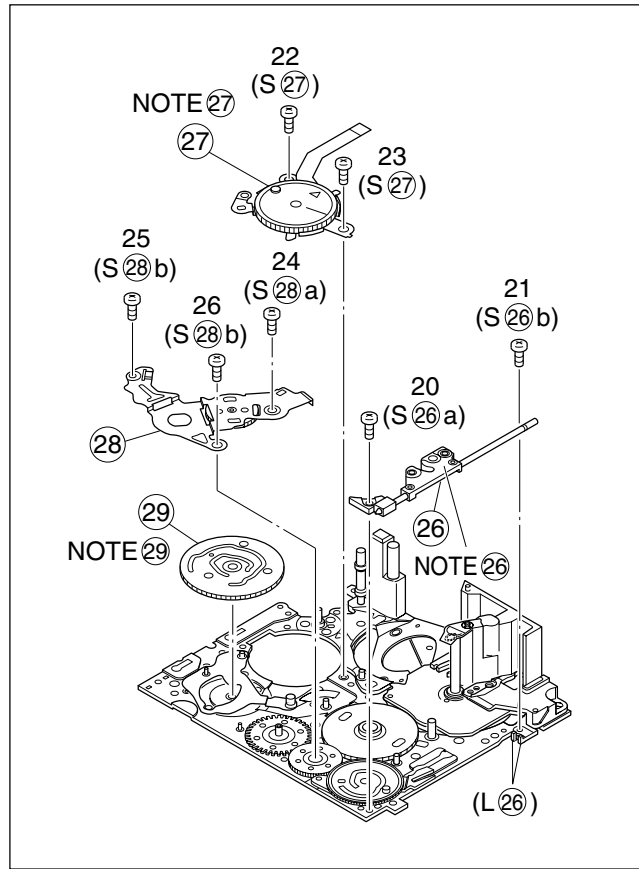
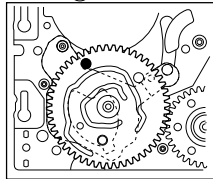


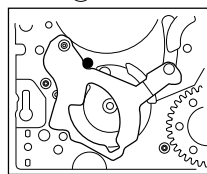
Fig. 2-4-10

- 10. 30 SLIDE ARM ASSY
- 31 CONNECT GEAR 2
- 32 SUB CAM ASSY
- 33 CONTROL ARM ASSY
- 34 REEL GEAR 1

NOTE 30:

When mounting, pay attention to the correct positioning and the FPC layout.

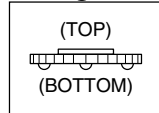
NOTE 30



NOTE 31:

When mounting, pay attention to the position of the front and back.

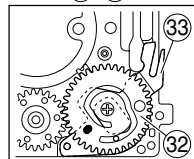
NOTE 31



NOTES 32/33/34:

When mounting, pay attention to the correct positioning and the FPC layout.

NOTE 32/33



NOTE 34

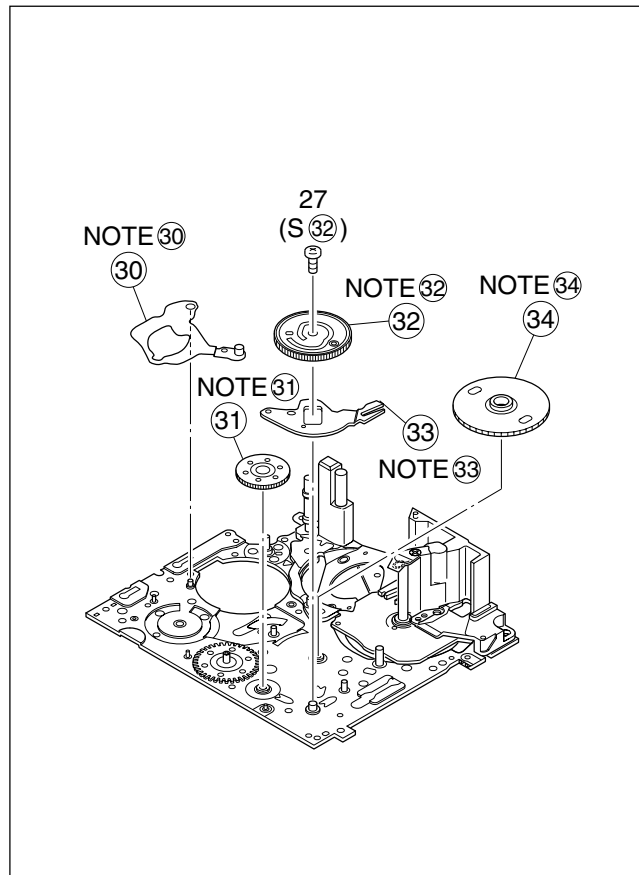
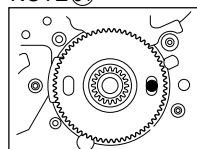


Fig. 2-4-11

- 11. 35 DRUM BASE ASSY
- 36 CAPSTAN MOTOR
- 37 MAIN DECK ASSY

NOTES 35 a / 36:

When detaching, remove them together and then separate 36 from 35a.

NOTE 35 b:

When mounting, attach the DRUM BASE ASSY so that the screw hole is located at the center of the ellipse.

NOTE 35 b

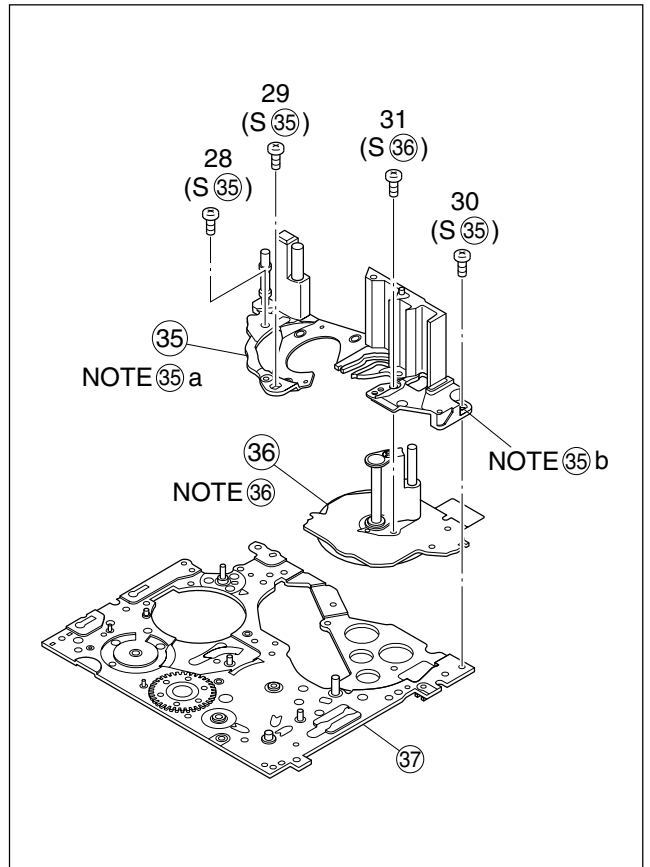
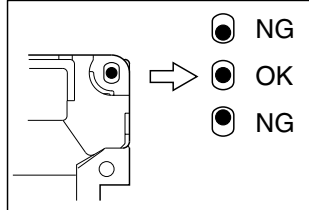


Fig. 2-4-12

2.4.2 List of procedures for disassembly

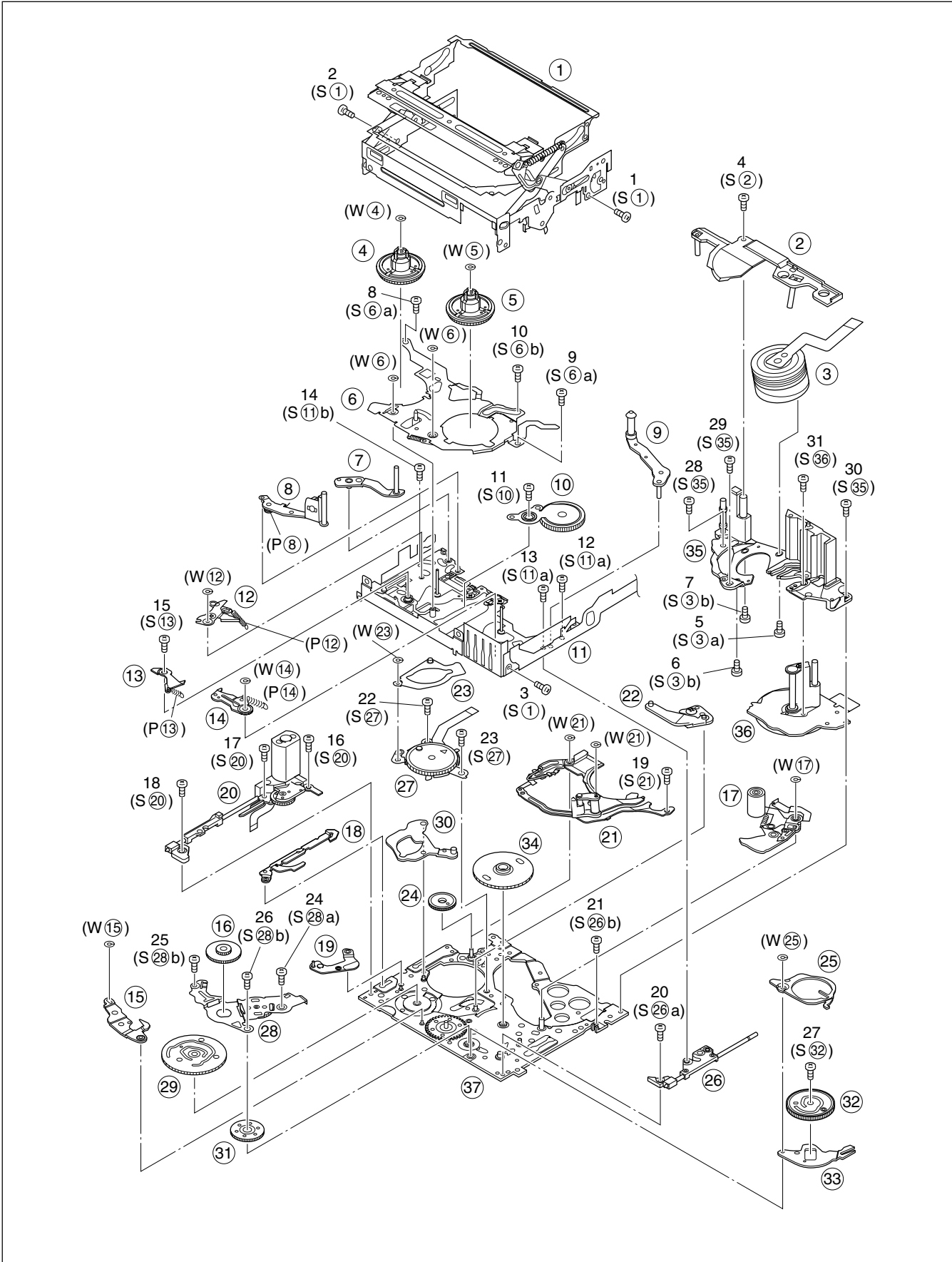


Fig. 2-4-13

2.5 CHECKUP AND ADJUSTMENT OF MECHANISM PHASE

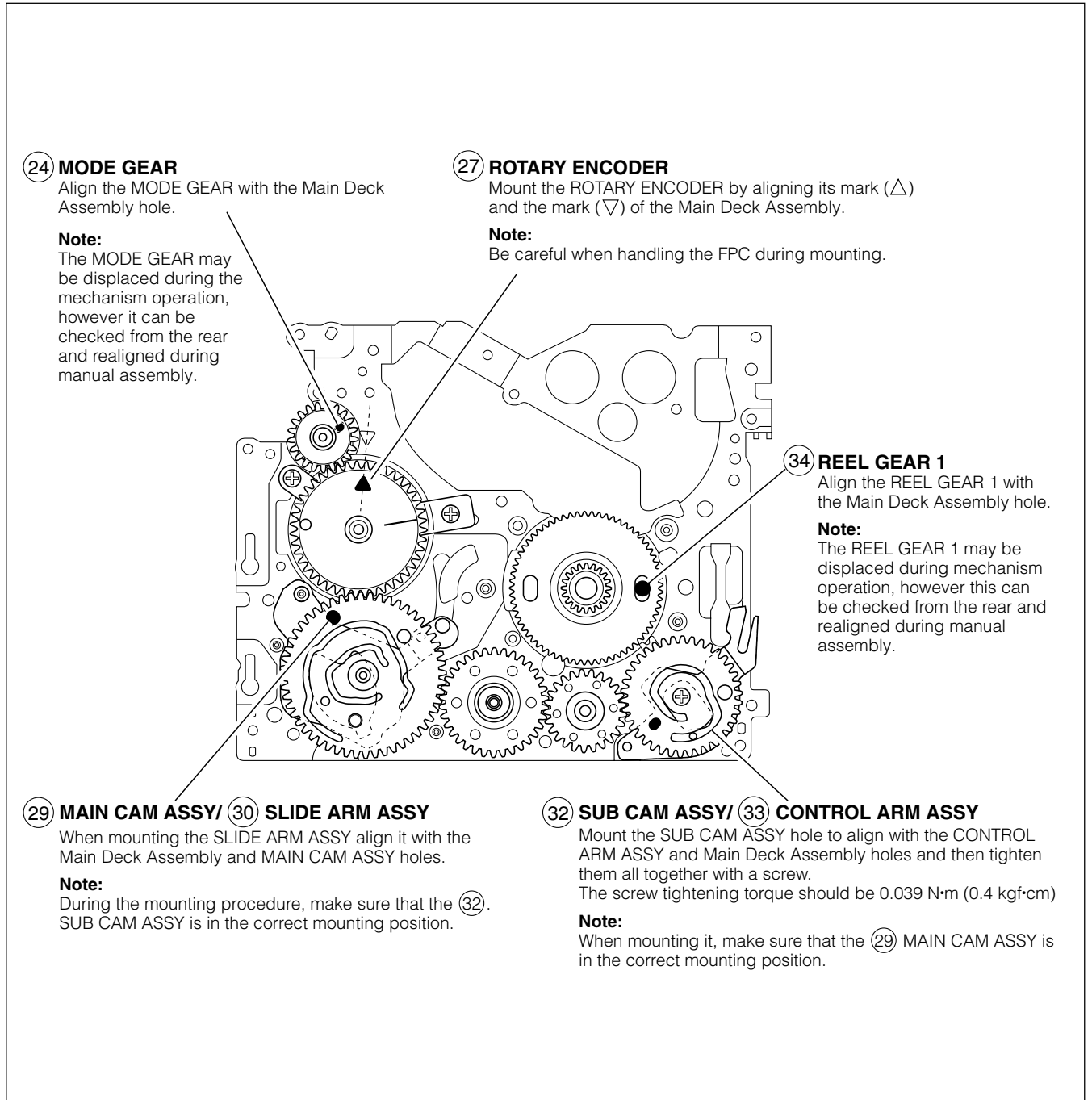


Fig. 2-5-1

2.6 MECHANISM ADJUSTMENTS

2.6.1 Adjustment of the slide guide plate

Use Fig. 2-6-1 as the reference unless otherwise specified.

1. Set the PLAY mode.
See Fig. 2-3-8.
2. Loosen the screws ((A),(B)).
3. With the Main Deck and Slide Deck Assemblies pushed into the unit, tighten the screws ((A),(B)) while applying pressure to the stud (shaft) on the Slide Guide plate.
The pressure applied should be enough to enable utilization of the rebounding force of the springs.
The tightening torque should be 0.069 N·m (0.7 kgf·cm).
4. Check the operation.
Repeat unloading and loading several times and make sure that these operations can be performed smoothly without producing rattles.

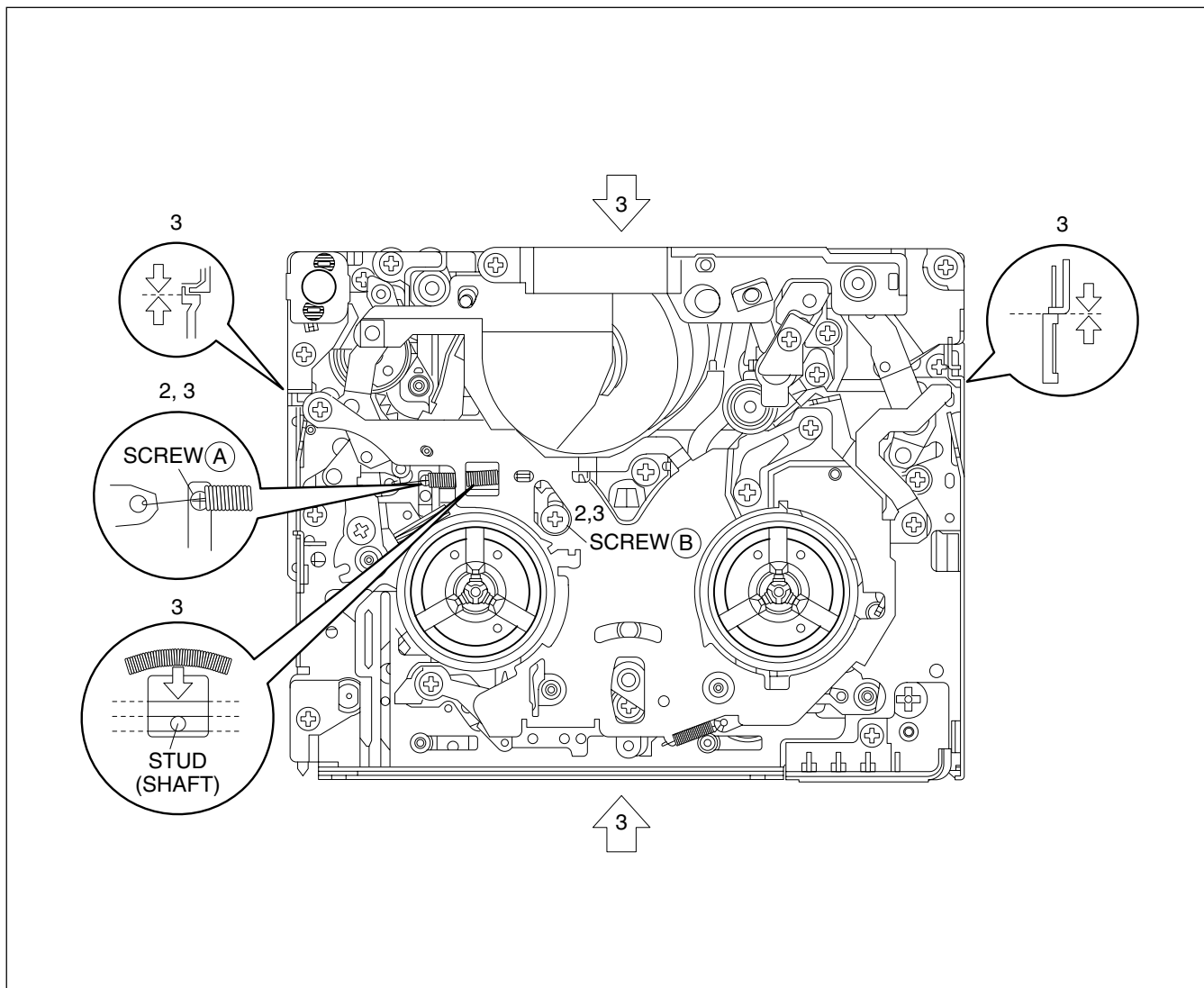


Fig. 2-6-1

2.6.2 Adjustment of the Tension Arm and Pad Arm Assemblies

Use Fig. 2-6-2 as the reference unless otherwise specified.

1. Set the PLAY mode.
See Fig. 2-3-8.
2. Loosen the screw (A).
3. With the take-up side at the bottom, align the extreme end of the Tension Arm Assembly with the crossed grooves on the screw (B) that retains the Loading Motor Assembly and then tighten the screw (A).
The tightening torque should be $0.069 \text{ N}\cdot\text{m}$ ($0.7 \text{ kgf}\cdot\text{cm}$).
4. Check the operation.
Repeat unloading and loading several times and make sure that the Tension Arm Assembly is located within the normal range.

Note : *With the above checking method, a Torque Meter is not used.
When a Torque meter is used, the following are the reference values:*

Back Tension : 1.96 to $5.88 \text{ mN}\cdot\text{m} \times 0.1$ (2 to $6 \text{ g}\cdot\text{cm}$)
Play Torque : 6.86 to $10.78 \text{ mN}\cdot\text{m} \times 0.1$ (7 to $11 \text{ g}\cdot\text{cm}$)

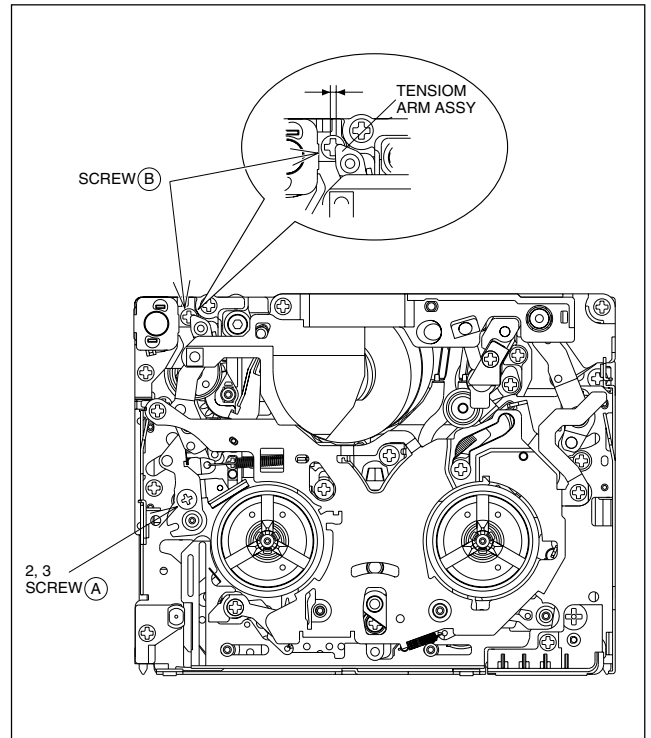


Fig. 2-6-2

2.6.3 Adjustment of the Slide Lever 2

Use Fig. 2-6-3 as the reference unless otherwise specified.

1. Set the C IN mode.
See Fig. 2-3-4.
2. Loosen the screw (A).
3. Set the Main Deck and Slide Deck Assemblies apart so that they do not rattle, then tighten the screw (A) by screwing it fully toward the Drum Assembly.
The tightening torque should be $0.069 \text{ N}\cdot\text{m}$ ($0.7 \text{ kgf}\cdot\text{cm}$).
4. Check the operation.
Repeat unloading and loading several times and make sure that these operations can be performed smoothly without producing rattles.

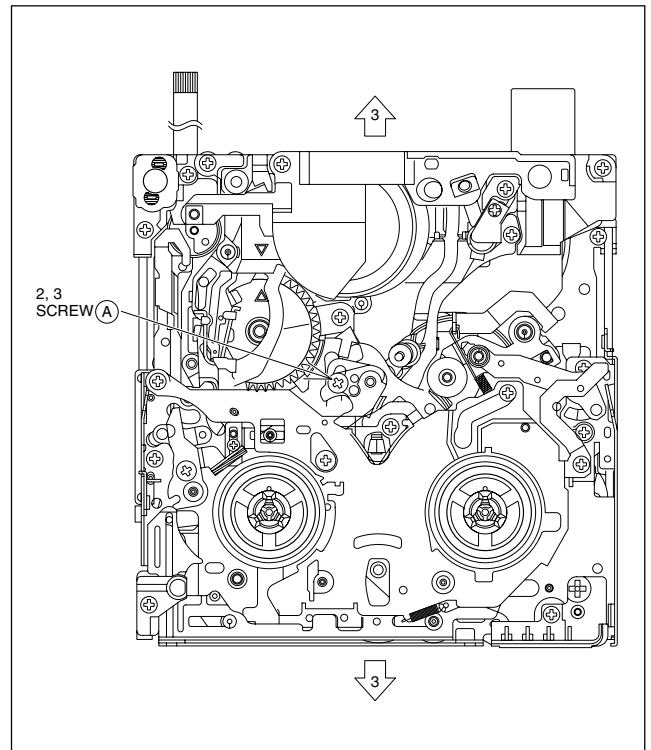


Fig. 2-6-3

2.7 JIG CONNECTOR CABLE CONNECTION

Remove one screw (1) first and the cover (JIG) next.

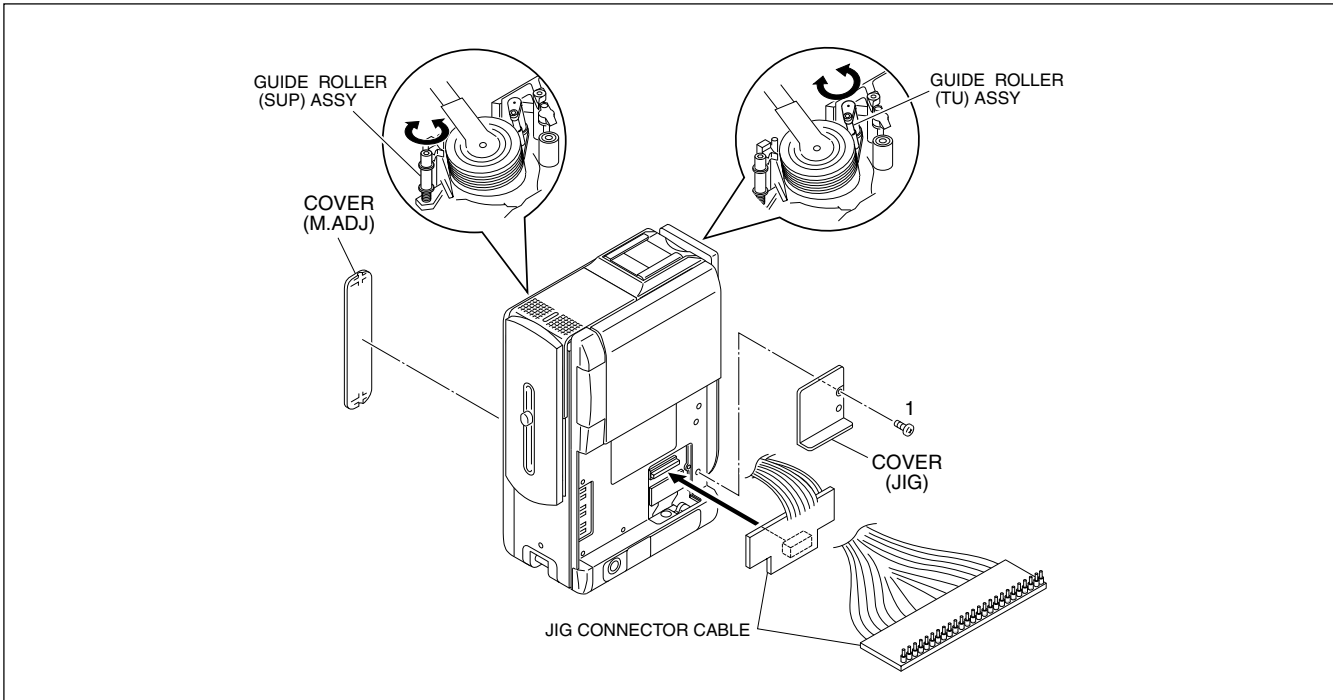


Fig. 2-7-1

MAIN CN114		JIG CONN. BOARD (PIN NO.)	
VF_RPD	40	40	VF_RPD
CVF_G	20	39	CVF_R
CVF_R	39	38	VF_COM
CVF_B	19	37	MT_G
VF_COM	38	36	MT_B
MT_RPD	18	35	MT_PSIG
MT_G	37	33	SBE
MT_R	17	32	FRP
MT_B	36	31	DISCRI
MT_COMCS	16	30	ATFI
MT_PSIG	35	29	ENV_OUT
GND	15	28	TRST
GND	34	27	TMS
MONI_CHG	14	26	TDI
SBE	33	25	JLIP_TX
SPA	13	20	CVF_G
FRP	32	19	CVF_B
FS_PLL	12	18	MT_RPD
DISCRI	31	17	MT_R
HID1	11	16	MT_COMCS
ATFI	30	15	GND
MAIN_VCO	10	14	MONI_CHG
ENV_OUT	29	13	SPA
PB_CLK	9	12	FS_PLL
TRST	28	11	HID1
TCMK	8	10	MAIN_VCO
TMS	27	9	PB_CLK
TDO	7	8	TCMK
TDI	26	7	TDO
JLIP_RX	6	6	JLIP_RX
JLIP_TX	25		
IF_TX	5		
AL_3VSY	24		
RST	4		
VPPC	23		
SRV_RX	3		
SRV_TX	22		
REG_3V	2		
DRST	21		
VPPD	1		

NOTE)

The JIG connector board uses 30 of the 40 pins of CN114 on the Main board.

Pins 1 to 5, 21 to 24 and 34 of CN114 on the Main board are not used.

Fig. 2-7-2

2.8 SERVICE NOTE

Use the following chart to manage mechanism parts that are removed for disassembling the mechanism.

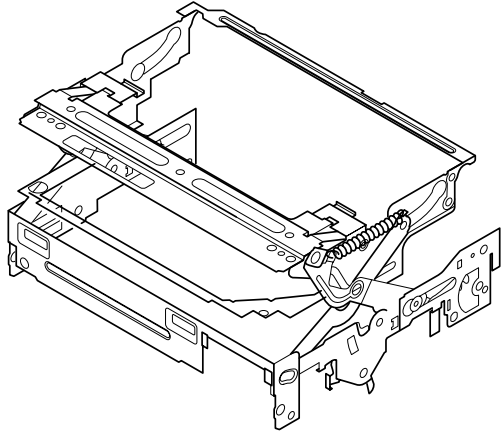
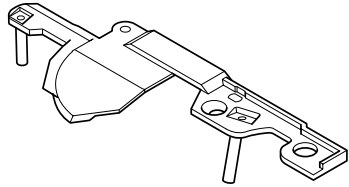
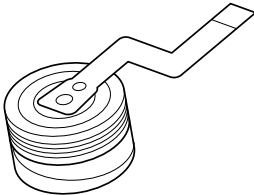
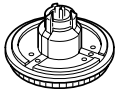
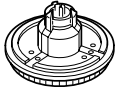
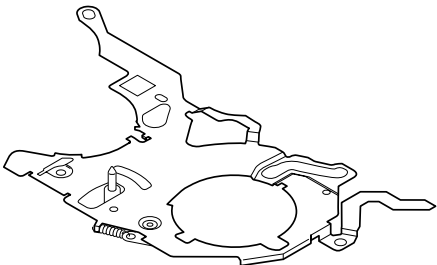

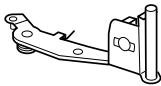
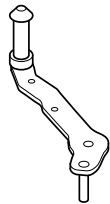

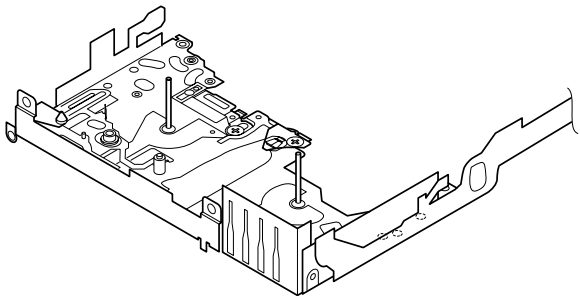


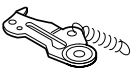
Fig. 2 4 3	① CASSETTE HOUSING ASSY 	Fig. 2 4 4	② UPPER BASE ASSY 			
Fig. 2 4 4	③ DRUM ASSY 	Fig. 2 4 5	④ REEL DISK ASSY(SUP) 	⑤ REEL DISK ASSY(TU) 	⑥ REEL COVER ASSY 	
Fig. 2 4 6	⑦ TENSION ARM ASSY 	⑧ SLANT POLE ARM ASSY 	⑨ TU ARM ASSY 	⑩ SWING ARM ASSY 		
Fig. 2 4 7 a	⑪ SLIDE DECK ASSY 		Fig. 2 4 7 b	⑫ PAD ARM ASSY 	⑬ SUP BRAKE ASSY 	⑭ TU BRAKE ASSY 

Table 2-8-1a

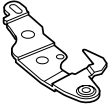

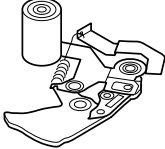
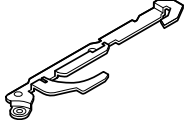

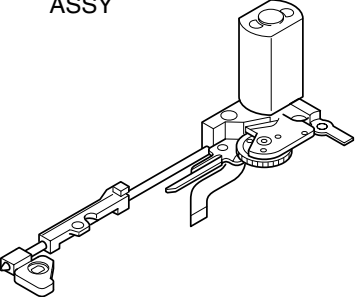
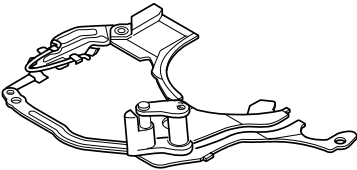



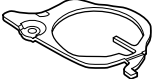
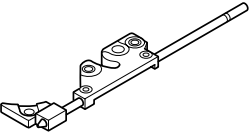
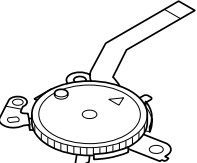
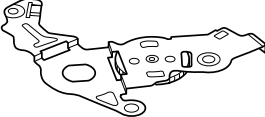

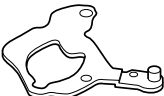



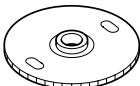
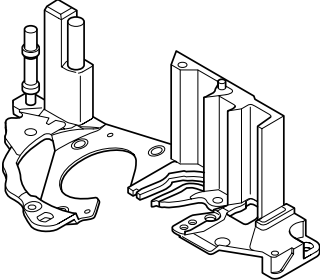
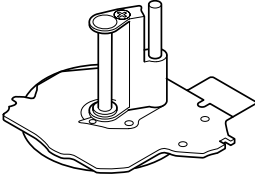
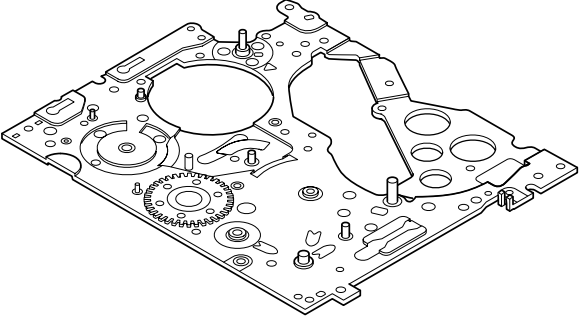
Fig. 2 4 8	15 TENSION CTL LEVER ASSY 	16 CENTER GEAR 	17 PINCH ROLLER ARM F. ASSY 	18 TENSION CTL PLATE ASSY 	19 BRAKE CTL LEVER ASSY 
Fig. 2 4 9	20 MOTOR BRACKET ASSY 		21 GUIDE RAIL ASSY 	22 SLIDE LEVER 2 ASSY 	23 LOADING PLATE ASSY 
				24 MODE GEAR 	25 EJECT LEVER 
Fig. 2 4 10	26 BASE R ASSY 	27 ROTARY ENCODER 	28 GEAR COVER ASSY 	29 MAIN CAM ASSY 	
Fig. 2 4 11	30 SLIDE ARM ASSY 	31 CONNECT GEAR 2 	32 SUB CAM ASSY 	33 CONTROL ARM ASSY 	34 REEL GEAR 1 
Fig. 2 4 12	35 DRUM BASE ASSY 		36 CAPSTAN MOTOR 	37 MAIN DECK ASSY 	

Table 2-8-1b

SECTION 3 ELECTRICAL ADJUSTMENT

3.1 PRECAUTION

1. Precaution

Both the camera and deck sections of this model needs a personal computer for adjustment except simple adjustment with potentiometers. If some of the following parts is replaced for repair or other reason, the repaired set must be adjusted with a personal computer.

- OP block
- E²PROM (IC1003 of MAIN board)

In the event of malfunction with electrical circuits, troubleshooting with the aid of proper test instruments must be done first, and then commence necessary repair, replacement and adjustment, etc.

1. In case of wiring to chip test points for measurement, use IC clips, etc. to avoid any stress.
2. Since connectors are fragile, carefully handle them in disconnecting and connecting.
3. Shortcircuit between operation un it and DECK chassis.

2. Required test equipment

1. Color TV monitor.
2. AC power adapter/charger
3. Oscilloscope (dual-trace type, observable 100 MHz or higher frequency)

Note : It is recommended to use one observable 300 MHz or higher frequency.

4. Digital voltmeter
5. Frequency counter (with threshold level adjuster)
6. Personal computer

3. Tools required for adjustments

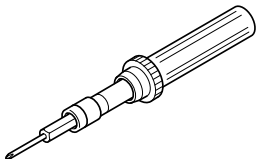
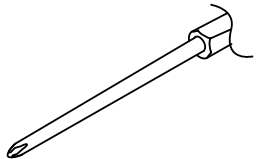
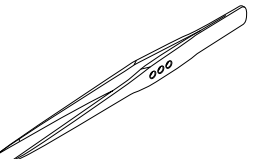
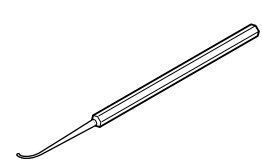
1	Torque Driver YTU94088	2	Bit YTS4088-003
			
3	Tweezers P-895	4	Chip IC Replacement Jig PTS40844-2
			

Table 3-1-1a

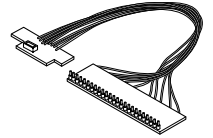
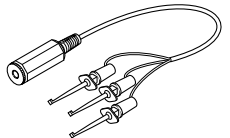
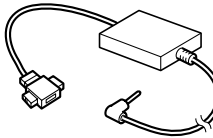
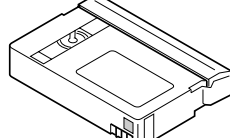
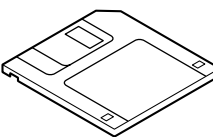
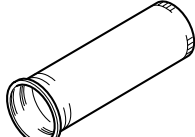
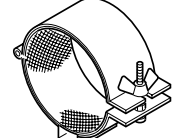
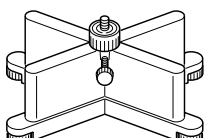
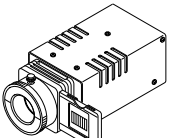
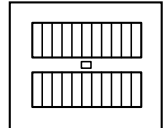
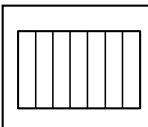

5	Jig Connector Cable YTU93106C	6	Communication Cable YTU93107A
			
7	PC Cable QAM0099-002	8	Alignment Tape MC-2
			
9	Service Support System YTU94057-54	10	INF Adjustment Lens YTU92001B
			
11	INF Adjustment Lens Holder YTU94087	12	Camera Stand YTU93079
			
13	Light box Assembly YTU93096A	14	Gray Scale Chart YTU94133A
			
15	Color Bar Chart YTU94133C	16	Cleaning Cloth KSMM-01
			

Table 3-1-1b

- 1. Torque driver**
Be sure to use to fastening the mechanism and exterior parts because those parts must strictly be controlled for tightening torque.
- 2. Bit**
This bit is slightly longer than those set in conventional torque drivers.
- 3. Tweezers**
To be used for removing and installing parts and wires.
- 4. Chip IC replacement jig**
To be used for adjustment of the camera system.
- 5. Jig connector cable**
Connected to CN114 of the main board and used for electrical adjustment, etc.
- 6. Communication Cable**
Connect the Communication cable between the PC cable and Jig connector cable when performing a PC adjustment.
- 7. PC cable**
To be used to connect the VideoMovie and a personal computer with each other when a personal computer is used for adjustment.
- 8. Alignment tape**
To be used for check and adjustment of interchangeability of the mechanism.
- 9. Service support system**
To be used for adjustment with a personal computer.
- 10. INF adjustment lens**
To be used for adjustment of the camera system.
- 11. INF adjustment lens holder**
To be used together with the camera stand for operating the VideoMovie in the stripped-down condition such as the status without the exterior parts or for using commodities that are not yet conformable to the interchangeable ring.
- 12. Camera stand**
To be used together with the INF adjustment lens holder.
- 13. Light box assembly**
To be used for adjustment of the camera system.
- 14. Gray scale chart (for Light box assembly)**
To be used for adjustment of the camera system.
- 15. Color bar chart (for Light box assembly)**
To be used for adjustment of the camera system.
- 16. Cleaning Cloth**
Recommended cleaning cloth to wipe down the video heads, mechanism (tape transport system), optical lens surface.

3.2 SETUP

1. Setup for electrical adjustment with personal computer.

NOTE: Remove one screw (1) first and the cover (JIG) next.

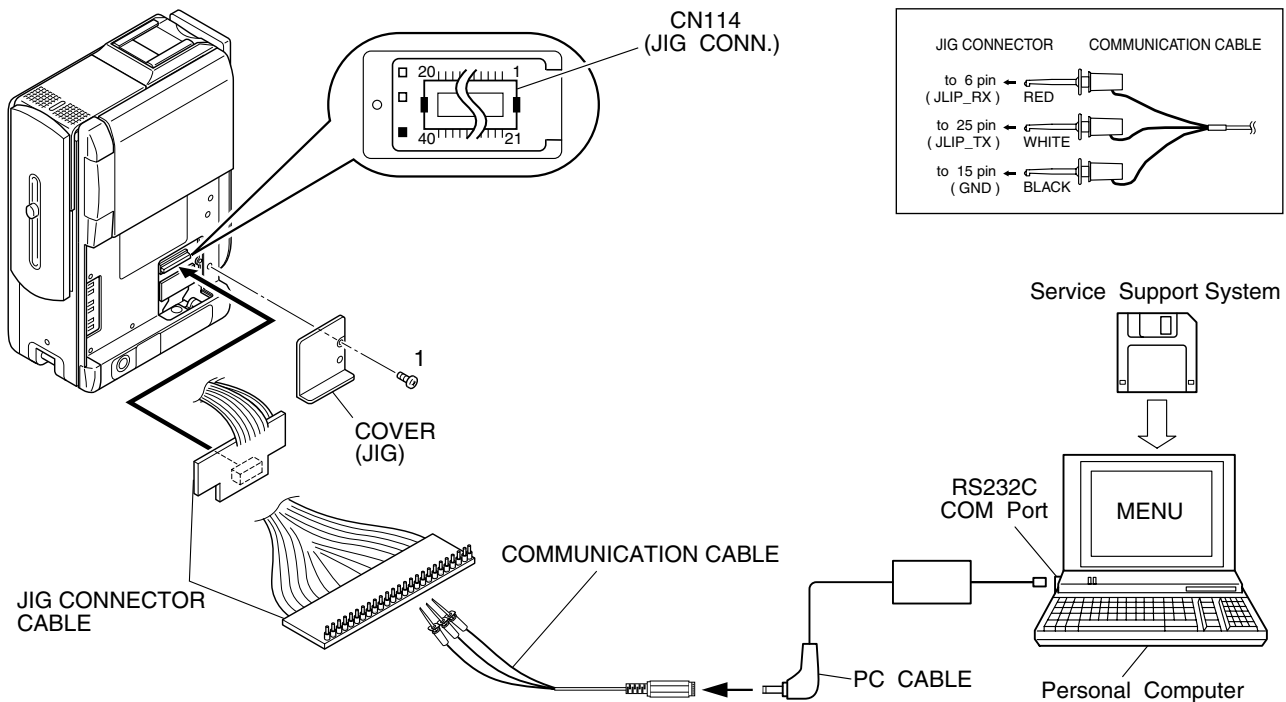


Fig. 3-2-1 Connection for Service support system